



ELECTROLUX MAJOR APPLIANCES NORTH AMERICA

# ***SERVICE MANUAL***

## ***2005 Dishwashers***

### ***PRECISION SELECT ELECTRONIC CONTROLS MODELS***

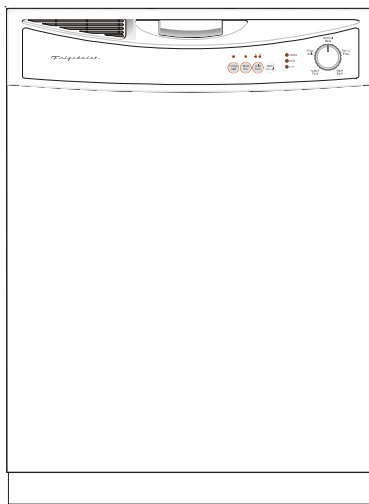

**FDB1050RE**

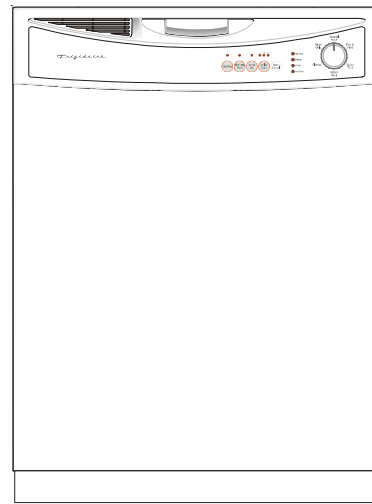

**FDB1250RE**

***Kelvinator*** 

***TAPPAN***<sup>®</sup>

***Gibson***<sup>®</sup>



**White-Westinghouse**<sup>®</sup>

***Frigidaire***

# SAFE SERVICING PRACTICES - ALL APPLIANCES

To avoid personal injury and/or property damage, it is important that **Safe Servicing Practices** be observed. The following are some limited examples of safe practices:

1. **DO NOT** attempt a product repair if you have any doubts as to your ability to complete it in a safe and satisfactory manner.
2. Before servicing or moving an appliance:
  - Remove the power cord from the electrical outlet, trip the circuit breaker to the OFF position, or remove the fuse.
  - Turn off the gas supply.
  - Turn off the water supply.
3. Never interfere with the proper operation of any safety device.
4. **USE ONLY REPLACEMENT PARTS CATALOGED FOR THIS APPLIANCE. SUBSTITUTIONS MAY DEFEAT COMPLIANCE WITH SAFETY STANDARDS SET FOR HOME APPLIANCES.**
5. **GROUNDING:** The standard color coding for safety ground wires is **GREEN**, or **GREEN** with **YELLOW STRIPES**. Ground leads are not to be used as current carrying conductors. It is **EXTREMELY** important that the service technician reestablish all safety grounds prior to completion of service. Failure to do so will create a hazard.
6. Prior to returning the product to service, ensure that:
  - All electrical connections are correct and secure
  - All electrical leads are properly dressed and secured away from sharp edges, high-temperature components, and moving parts
  - All non-insulated electrical terminals, connectors, heaters, etc. are adequately spaced away from all metal parts and panels
  - All safety grounds (both internal and external) are correctly and securely connected
  - All panels are properly and securely reassembled

## ATTENTION!!!

**This service manual is intended for use by persons having electrical and mechanical training and a level of knowledge of these subjects generally considered acceptable in the appliance repair trade. Electrolux Home Products cannot be responsible, nor assume any liability, for injury or damage of any kind arising from the use of this manual.**

# TABLE OF CONTENTS

<b>SAFE SERVICING PRACTICES .....</b>	<b>I</b>
---------------------------------------	----------

## **COMPONENT OPERATION**

Precision Select Control .....	4
Wash Systems .....	4
Spraying from Center .....	5
Filter-Polypropylene .....	5
Water Distribution Components .....	6
Wash Motor .....	6
Upper Spray Arm-precision Wash .....	6
Precision Direct .....	6
Lower Spray Arm .....	6
Drain Pump .....	7
Drying System .....	7
Heater .....	7
Fill System .....	8
Dispensing System .....	8
Dispenser Operation .....	8
Temperature Controls with Thermistor .....	9
Cycles .....	9
Pots/Pans .....	9
Normal Wash .....	10
Light/Econo Wash .....	10
Upper Rack .....	10
Rinse Only .....	10
Glasses .....	10
Electronic Control .....	10
Options .....	10
Sanitize Rinse .....	10
Hi-Temp Wash .....	10
Heated Dry .....	10
Delay Start .....	11
Start/Cancel .....	11

## **DISASSEMBLY AND SERVICE**

Safety Precautions .....	12
Control Panel .....	12
Precision Select Electronic Control .....	12
Vent Housing Assembly .....	12
Door Latch .....	13
Detergent/Rinse Aid Dispenser .....	13
Door Seal .....	13
Upper Rack .....	13
Center Spray Arm (Precision Direct Models) .....	13
Heating Element .....	14
Float Switch and Mount Bracket .....	14
Water Valve .....	14
Drain Pump .....	14
Precision Wash .....	14
Precision Direct Wash System .....	14
Delivery Tube .....	15
Precision Wash .....	15
Precision Direct Wash System .....	15

Pump and Motor Assembly .....	15
Precision Wash .....	16
Precision Direct Wash System .....	16
Remove Motor from Sump .....	16
<b>TROUBLESHOOTING TIPS .....</b>	<b>17</b>
<b>TECHNICAL SPECIFICATIONS .....</b>	<b>19</b>
<b>EXPLODED VIEW DIAGRAMS .....</b>	<b>A1</b>
<b>Model FDB1050RE</b>	
Control Panel .....	A2
Door .....	A3
Tub .....	A4
Motor & Pump .....	A5
Frame .....	A6
Racks .....	A7
<b>Model FDB1250RE</b>	
Control Panel .....	A8
Door .....	A9
Tub .....	A10
Motor & Pump .....	A11
Frame .....	A6
Racks .....	A12
<b>SERVICE DATA SHEETS</b>	
154547801 - Models FDB1250RE (BSQ0) .....	B1
154547901 - Models FDB1050RE (BSQ0M) .....	B3

# COMPONENT OPERATIONS

## PRECISION SELECT CONTROL



FDB1250RE



FDB1050RE

The new Precision Select Control is an electronic control which uses a knob mounted selector switch to select the desired wash cycle in place of a keypad assembly. The knob mounted selector switch can be turned both clockwise and counter clockwise to select a cycle. The variety of cycles will vary depending on model; however, the Normal wash will always be at the twelve o'clock position on the selector switch.



6 position cycle selector



5 position cycle selector

To the left of the selector is a start pad along with any options the model may have. Each option pad has an LED that will illuminate when the option is selected. Between the option pads and the selector are status lights to illuminate progression of the cycle operation. For models that offer a sanitize rinse option, there is a sanitize light to indicate when this cycle is completed properly. A cycle is started by the selector switch being turned to the desired cycle, any options desired selected, and the Start/Cancel pad pressed.

If desired the start of a cycle can be delayed by pressing the Delay start pad. Pressing this pad multiple times will increase the number of hours the start of a cycle is delayed. When using this option the Start/Cancel pad is not pressed. Operation of the control and testing will be covered in later sections.



Options for FDB1250RE



Options for FDB1050RE

## WASH SYSTEMS

Dishwasher models incorporating either the Precision or the Precision Direct wash systems can be adapted to use this Precision Select Control. The operation of the Precision and the Precision Direct wash systems are the same with differences only in the location of certain components. Both systems are designed to operate with only one spray arm at a time. The alternating of the spray arms will start in the pre-wash and can change in 90 seconds increments throughout the cycles.

The alternating of the spray arms is achieved with a check ball located on a ramp between two water outlets from the sump. There is an outlet in the center of the sump for the bottom spray arm. Then a second opening for the center spray arm, that on the Precision direct models also supplies water to the upper shower nozzle. Pictured below are the two sumps with the check ball in the starting position.



Precision Wash



Precision Direct

The cycle starts with the check ball in the normal position resting at the bottom of the ramp covering the outlet for the upper arm. The outlet is not covered completely by the ball, some water does bypass the ball entering the delivery tube for the upper arm. The majority of the water leaves from the center opening, into the lower spray arm; washing is now into the lower rack.

Opening for water to by-pass check ball

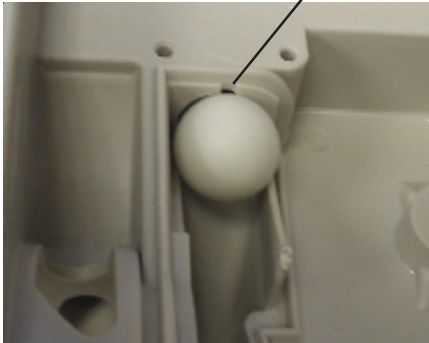

### SPRAYING FROM CENTER

To change the spray to the center, the control pauses the wash motor for not more then .6 of a second. During the pause, water pressure on the back of the check ball decreases, this allows the water located in the delivery tube to reenter the sump. The check ball is moved away from the opening by the returning water and is forced up the ramp. Now the wash pump restarts, this creates water pressure in front of the check ball moving it up into the center outlet stopping the lower spray arm.



Check ball moved up ramp.

Water exits out the side outlet leading to the center arm and the upper rack. Water sprayed from the center spray arm sprays both into the upper rack and down onto the lower rack. At the same time, the shower nozzle in top of the tub sprays water down onto the upper rack.

To return spray to the lower spray arm, the pump is paused for 3 seconds. This longer pause allows all of the water to drain back into the sump from the delivery tube and the check ball to fall back down the ramp to recover the side outlet hole. This completes the change cycle. This cycling between the spray arms continues in all wash and rinse cycles.

### FILTER

#### *Polypropylene filter*

This is a molded filter which covers the complete sump area. The center of the filter has an inner basket to direct food to the drain section of the sump. This inner basket has sides constructed of a fine polyester mesh and a solid bottom to keep food soil from entering the water distribution system. The filter is locked in place with the lower spray arm support.



Inner basket with soil director



Top of filter with spray arm support locked in place

## WATER DISTRIBUTION COMPONENTS

### WASH MOTOR

Both wash systems will use the same motor, a 120VAC fed DC brush style motor. This motor has a built-in rectifier to change the AC voltage to DC. The wash motor provides water under pressure for spraying as well as turning the spray arms.



### UPPER SPRAY ARM

#### PRECISION WASH

The upper spray arm hangs from a bracket that snaps into the upper rack. Water is supplied to the upper arm from the sump by a delivery tube to the top of the tub entering a funnel in the center of the upper rack under which is the upper spray arm. As water enters the spray arm, the holes are set to cause the arm to turn.

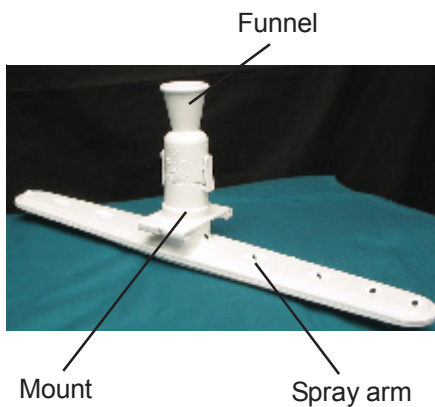

### PRECISION DIRECT

The center spray arm is mounted to a delivery tube on the under side of the upper rack. This assembly moves in and out with the rack. On the rear of the delivery tube is a bellows which acts as a seal between the delivery tube and the rear wall of the tub. When water under pressure enters the spray arm / delivery tube assembly, the bellows expands insuring there is no loss of water pressure for turning the center spray arm. The Precision direct models also have a shower nozzle mounted to the top of the tub. This nozzle sprays water down onto the upper rack as the center arm is turning.

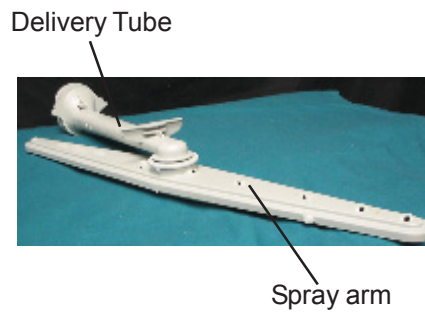

### LOWER SPRAY ARM

The lower spray arm rotates on a lower spray arm support. The lower arm has two functions: washing the dishes in the lower rack and cleaning off the top of the filter. Jets on top of the spray arm propel the arm while spraying water into the lower rack. On the bottom side of the lower arm are three legs. The two out side legs will spray across the top of the filter moving dislodged food partials to the center of the filter. The third leg is mounted closer to the center of the filter this leg sprays water down into a center filter basket to help move this loosened food to the back section of the sump to be removed in the drain cycle.

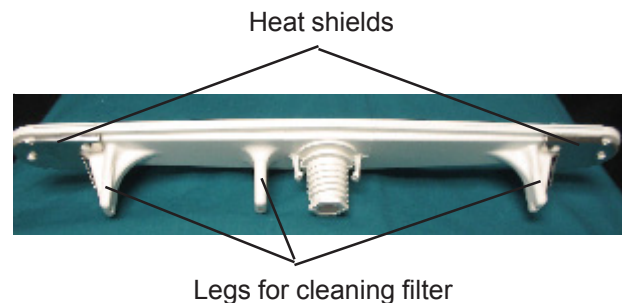

## DRAIN PUMP

Both wash systems use a separate drain pump; however the mounting and location of the drain pumps are different. The drain pump for the Precision Wash system is mounted to the underside of the tub to the right of the sump. Water enters the front of the drain pump by a short connecting hose from rear section of the sump. On the Precision Direct system, the drain pump is mounted directly to the front of the sump. Water enters the front of this pump by a short connecting hose to the rear of the sump area. Both pumps are dual directional so it can run either clockwise or counter clockwise. The front cover of either pump can be removed if needed for cleaning.

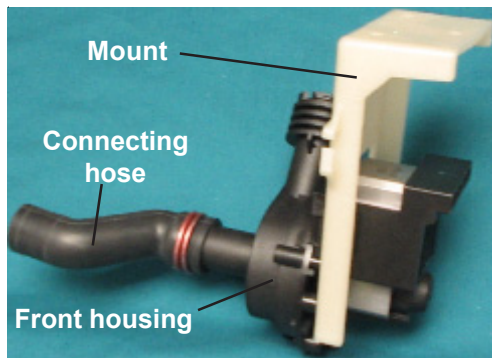

Drain pump and mount for Precision wash system

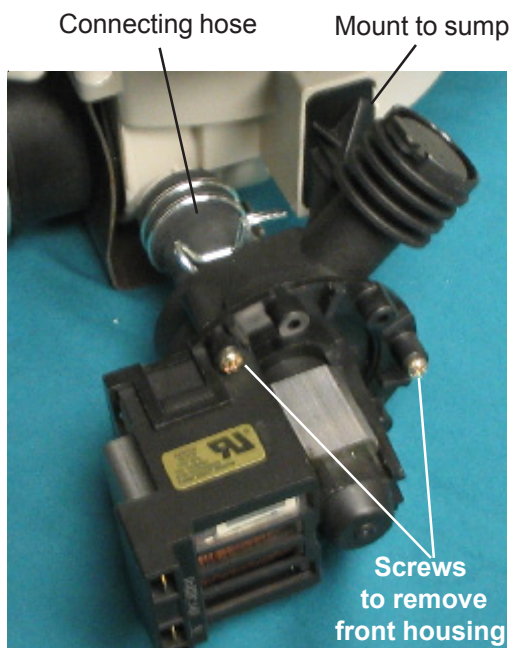

Drain pump mounted to the sump on the Precision direct wash system

## DRYING SYSTEM

Drying dishes in these models is accomplished with a basic convection dry system. A vent housing mounted to the top left side of the inner door panel has a fixed baffle that reduce the sounds from washing and prevents water from being sprayed out while the center spray arm is in operation. This baffle has a one point mount that allows steam and heat to be released without obstruction. The housing is mounted to the inner door panel using three screws. There is a foam gasket between the housing and panel that is glued in place to prevent water leaks.

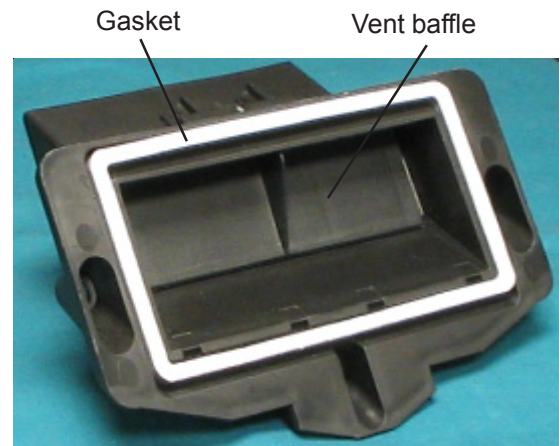

## HEATER

The heating element used in the dishwasher is mounted to the bottom of the tub with two stainless steel mounting brackets. The purpose of the heater is to improve drying, and maintain the water temperature throughout the complete wash cycle. This heater can also be used to increase the water temperature if the high temp options are selected. The heater used is a PTC design element. This element allows the wattage to vary depending on the task it is to perform. When water is to be heated the wattage draw of the heater will be approximately 900 watts. If the element is used in the dry cycle, the



wattage drops to approximately 700 watts. This design makes the heater more energy efficient. There are two different shaped heaters used in these products but both function the same. Along with the heater, there is also a safety thermostat that is mounted under the tub on the left side. This thermostat will open if the tub temperature raises over 200° F. It will reset after the tub temperature drops below 100°F. This is to protect the dishwasher tub.



Heater for the Precision wash system

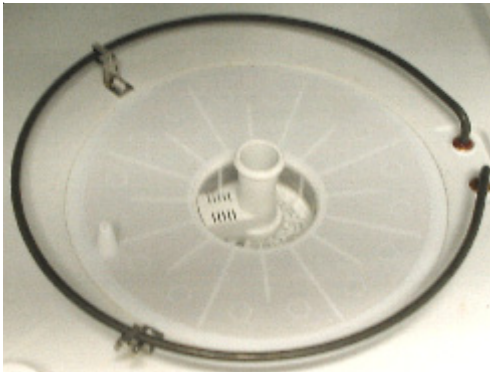

Heater for the Precision direct wash system



Safety  
Thermostat

## FILL SYSTEM

The fill system consists of the water fill valve and a float safety switch. The water valve is an electrically operated shut off valve having also a built-in flow washer. The purpose of the flow washer is to regulate the quantity of water leaving the valve based on the water pressure applied to the valve inlet. To insure there is proper water flow into the tub, the water pressure to the valve needs to be between 20 and 120 psi. The amount of water used is determined by the electronic control. The float safety switch is used to stop power to the water valve if the

tub is over filled for any reason. Water from the water valve enters the tub from the left side through an air gap mounted to the side of the tub.

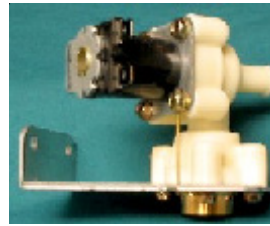

Water valve

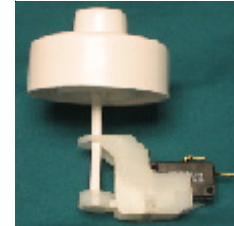

Float and  
Float switch



Water bottle on  
side of tub

## DISPENSING SYSTEM

The dispenser assembly combine two dispensers using one common wax motor actuator. One dispenser is for wash detergent the other for rinse aid. The dispensers are actuated by the electronic control energizing the common wax motor actuator. First to be dispensed is the detergent, this is done in the main wash cycle. The rinse aid is released in the last rinse cycle just before the dry cycle. The rinse aid dispenser can be adjusted by the consumer by removing the filler cap and changing the setting found in the dispenser opening. The dispenser assembly is replaced as a complete assembly. The only individual replacement part for this assembly is the filler cap.

## DISPENSER OPERATION

The dishwasher has two detergent cups. One is for pre-wash detergent. This cup can be molded into the inner door panel or a partitioned off section under the detergent dispenser cover. The second cup is in the dispenser covered by a spring loaded cover. This cover can be released manually or automatically by the control.

Prior to starting a wash cycle the proper amount of detergent is added to the dispenser cups then the cover is closed and latched properly. Models having the open pre-wash cup molded in the inner door panel will have the detergent drop into the tub once the door is raised to the upright position. Those models having the pre-wash cup in the dispenser have openings cut in the cover that allow the detergent to enter the tub once the dishwasher door is closed.

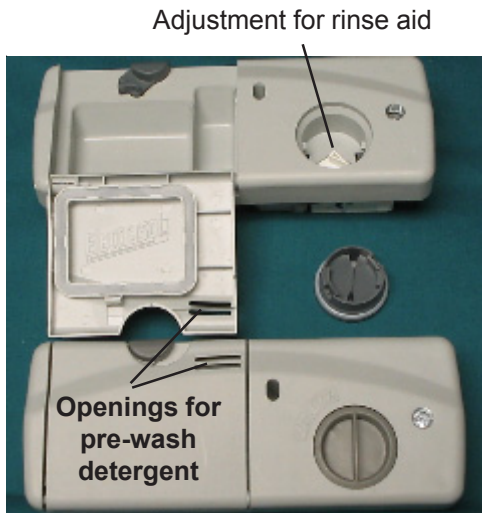

Dispenser with molded in pre-wash cup

At the beginning of the main wash cycle, power is applied to the wax motor actuator for one minute. This causes the wax motor to heat resulting in the actuator plunger of the wax motor to extend. This plunger pushes down on a pivot arm. The pivot arm in turn releases the spring loaded detergent cover allowing the detergent to enter the tub for the main wash. The plunger of the wax motor can extend far enough in 30 seconds to release the cover to dispense the detergent. The extra time is needed to position the opposite end of the pivot arm to later dispense the rinse aid. Power is removed from the wax motor for the plunger to retract. A spring on the pivot arms returns it to the normal (horizontal) position. As the detergent cover is released on the opposite end of this pivot arm a pin moves up in a slot of the rinse aid injector pump arm. This slot is formed so when the pivot arm releases the detergent cup cover the upward movement does not raise the rinse injector pump arm enough to release the rinse aid at the wrong time. In the last rinse, the control powers the wax motor once more. The plunger extends moving the opposite end of the pivot arm up causing the pin to raise the rinse aid injector pump arm, this releases rinse aid into the tub. Finally, power is removed from the wax motor, the plunger retracts and the pivot arm raises. At the same time, next to the rinse aid injector arm is a leaf spring that returns the injector arm to the original starting position.

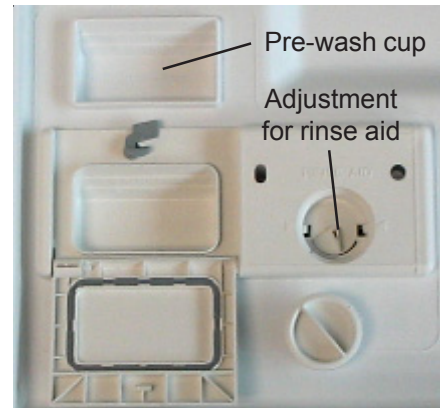
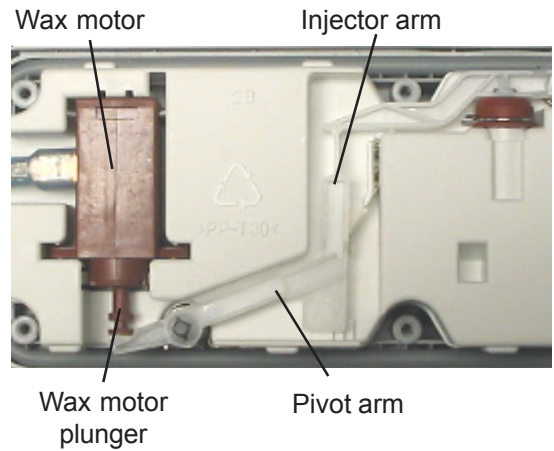

## TEMPERATURE CONTROLS WITH THERMISTOR

A Thermistor is used by the electronic control to sense the temperature of the water. The electronic control is programmed with an assured water temperatures in select cycles to insure the proper cleaning of the load. If these temperatures are not present the control will pause the cycle to allow the water temperature to increase. This function is accomplished with information received from the thermistor. The options that can be selected for high temperature wash, high temperature rinse or sanitize rinse are also accomplished with information received from the thermistor. The assured water temperature can vary depending on cycle. The following list give the assured temperature and available options for each cycle.

### CYCLES *Pots/Pans*

This cycle is designed for Pots/Pans or your heavier soiled dishes. The control automatically selects an assured water temperature of 140° in the main wash and 155° in the final rinse. The Hi-Temp WASH and the SANITIZE rinse are automatically selected and cannot be disabled. The lights over the option pads for these options will be on as well as the Heated Dry lit.

## **Normal Wash**

This cycle is designed for normally soiled dishes. The control automatically selects an assured water temperature of 135° in the main wash and 140° in the final rinse. All options are available. When the cycle is started the light over the Heated Dry pad will be lit.

## **Light/ Econo Wash**

This cycle is designed for lightly soiled dishes. The control automatically selects an assured water temperature of 135° in the main wash and 140° in the final rinse. All options are available. When the cycle is started the light over the Heated Dry pad will be lit.

## **Upper Rack**

This cycle is used for small loads of glassware or cups etc. The control automatically selects an assured water temperature of 135°F in the final rinse. The option for Hi Temp wash and Sanitize rinse can not be selected. The light over the Heated Dry pad will be lit.

## **Rinse only**

This cycle is to rinse the dishes where no detergent will be used. The only option that can be used is the delay start.

## **Glasses**

This cycle is used for lighter more delicate items. The control automatically selects an assured water temperature of 125°F in the main wash then 130°F for the final rinse. The option for Hi Temp wash and Sanitize rinse can not be selected. The light over the Heated Dry pad will be lit.

## **ELECTRONIC CONTROL**

The Electronic Control controls all of the operation of the dishwasher. Power to operate this control comes directly from the incoming power supply to the product. A second power line from the door switch also enters the control to supply current used in operating all other function of the dishwasher. In this manor, if the door is opened in a cycle the dishwasher will stop but the cycle will not be canceled. If servicing this product, care must be taken due to the operating voltage of this control being 120VAC. When diagnosing the control operation, the water service test can be used to operate all of the components in the dishwasher without selecting a wash cycle. Power supplied to the functional components by the control can also be checked at the disconnect block inside the door without removing the console. To start the Water Service Test all cycles must be cleared and all of the lights out on the console, turn the Cycle Selector to the Rinse Only setting, press and hold the Heat Dry and the Start/ Cancel pads

simultaneously for 3 seconds or less the test will start by powering the water valve. With the test started, the operation sequence can be follow with the chart entitled Water/ Service Test.

**For any service or to replace any operating component always disconnect power to the product.**

## **OPTIONS**

All of the options pads are part of the electronic control and are changed with the control.

### **Sanitize Rinse**

When this option is selected, the control will automatically delay the end of the main wash and raise the temperature to 140°F but the light over the Hi-Temp wash pad will not come on. Then in the final rinse the cycle will be delayed to raise the temperature to 155°F for the Sanitize option. The maximum time for the wash delay will be 10 minutes, the delay in the last rinse will be 40 minutes maximum. This is intended to aid in getting the 155°F temperature in the final rinse for the Sanitize to come on at the proper time. Upon successfully completing the Sanitize Rinse and the water has reached the 155°F temperature the Sanitized LED will come on in conjunction with the Clean LED at the end of the cycle. If the door is opened during the final rinse or the incoming water temperature drops below 120°F, the sanitization may not occur in which case the sanitize light will not come on when the cycle is completed.

### **Hi-Temp Wash**

When this option is selected the control will delay the main wash cycle to allow the heater to raise the water temperature to 140°F. The control will also delay the last rinse to increase to increase this temperature to 145°F. Even though the temperature is raised in the rinse cycle the light for the Hi-Temp rinse will not come on unless the option is select. The maximum delay time will be 10 minutes per delay.

### **Heated Dry**

This option light will come on whenever the cycle is started in all cycles that include a dry section. The Heated dry option can be deselected at any point prior to the termination of the dry cycle.

### Delay Start

Prior to a cycle being started a Delay start can be selected. To select a delay Start tapping the pad will advance the control through the time of delay for this model. Once the delay time has been selected the count down will begin. To cancel the Delay option and regain the cycle before the delay period is over; press the Start/Cancel pad.

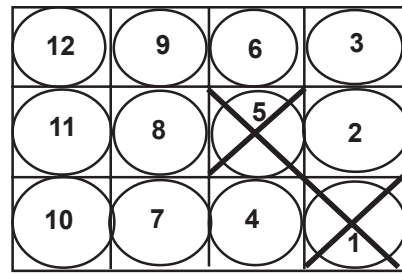

Control half of disconnect block

### Start/Cancel

Press the Start/Cancel pad will activate any cycle selection. At any time during a cycle, pressing the Start/Cancel pad cancels the cycle and initiates a 90 second drain cycle and ends the cycle.

### Pin location in

Disconnect block	Load
1	Empty
2	Power for control
3	From door switch
4	Safety Therostat
5	Empty
6	Dispenser
7	Thermistor
8	Drain pump
9	Nuetral
10	Thermistor
11	Float Switch
12	Wash motor

STEP	DESCRIPTION	TIME (SEC)	WATER VALVE	WASH MOTOR	DRAIN MOTOR	HEATER	DISPENSOR	WASHING LED	ACTIVE VENT	DRYING LED	SANITIZED LED
1	FILL/ DISPENSOR	60	1	0	0	0	1	1	1	0	0
2	FILL	27	1	0	0	0	0	1	1	0	0
3	WASH/HEAT	45	0	1	0	1	0	1	1	0	0
4	PAUSE	0.6	0	0	0	1	0	1	1	0	0
5	WASH/HEAT	75	0	1	0	1	0	1	1	0	0
6	WASH/HEAT/DISP	60	0	1	0	1	1	1	1	0	0
7	DRAIN	90	0	0	1	0	0	1	0	0	0
8	DRY	90	0	0	1	1	0	0	0	1	0
TOTAL		448						0	0	0	1
CLEAN LED and SANITIZED LED- stay on until door is opened or cycle started											

# DISASSEMBLY AND SERVICE

## SAFETY PRECAUTIONS

Always turn off electrical power supply before servicing any electrical component, making ohmmeter checks, or making any part replacement. Refer to safe servicing procedures at the front of this service manual before servicing the dishwasher.

All voltage checks should be made with a voltmeter **having a full scale range of 130 volts or higher.**

After service is completed, be sure all safety grounding circuits are complete, all electrical connections are **secure, and all access panels are in place.**

## CONTROL PANEL

1. Disconnect the dishwasher from electrical supply.
2. Remove the outer door panel;
3. The outer door panel is held to the inner door panel by two screws and four locking tabs, two on each side of the door.
4. Remove the lower two screws, one on each side that secures the outer door to the inner panel.
5. Close the door and slide the door panel down and outward to remove.
6. **Remove the six screws mounting the control panel to the inner door.**

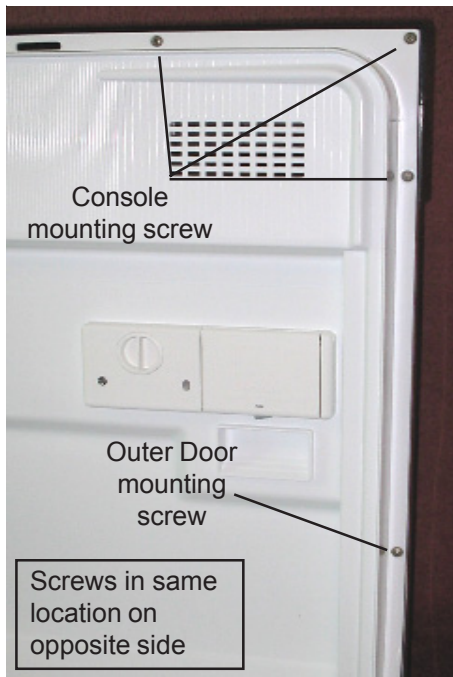

## DAIL-O-MATIC ELECTRONIC CONTROL

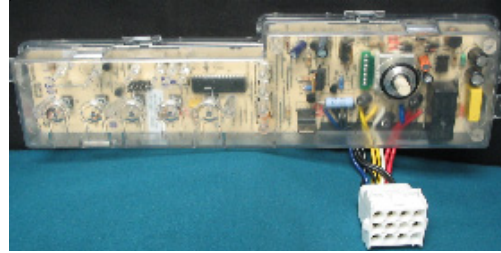

1. Disconnect the dishwasher from electrical supply.
2. Remove knob from selector by pulling straight off
3. Remove outer door panel
4. Separate wire connection at control
5. Remove console
6. On top of control case pull back plastic clip holding control in place, pull control assembly from console.

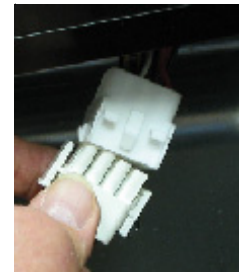

Control mounting clip

Wire Connection



## VENT HOUSING ASSEMBLY

1. **Disconnect the dishwasher from electrical supply**
2. Remove outer door panel
3. Remove console
4. Remove three screws holding assembly to inner door panel, remove any gasket remaining from old cover.
5. Remove gasket protection paper from new housing
6. Place new cover at an angle onto bottom vent housing supports raise up into place. This is to insure bottom of the gasket seals properly to inner door panel.

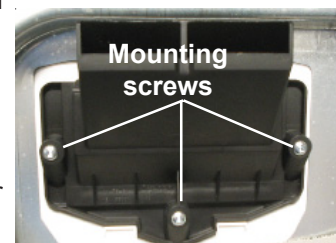

## DOOR LATCH

1. **Disconnect the dishwasher from electrical supply**
2. Remove outer door panel
3. Remove console
4. Remove wires from both door switches
5. Remove two Torx screw holding latch
6. **Make sure both white wires are on one switch and both black wires are on the opposite switch.**

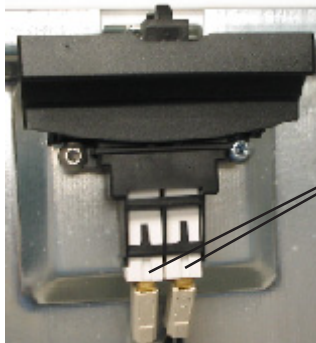

Door  
Switches

## DETERGENT/ RINSE AID DISPENSER

1. Disconnect the dishwasher from electrical supply
2. Remove outer door panel
3. Disconnect wiring from dispenser
4. **Remove six Phillips screws and carefully push dispenser into the tub**

Mounting Screws

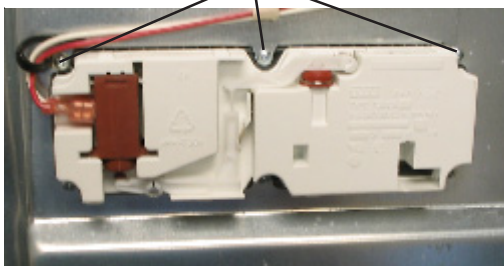

Hook opened to  
remove retainer

## DOOR SEAL

1. Door seal just pulls out of channel around tub.
2. To replace find center of gasket make sure back goes into channel first. Back is marked with a color stripe.
3. Starting at center top press gasket into channel just to hold in place
4. Go to bottom on either side find block molded into bottom of tub fill block with gasket.

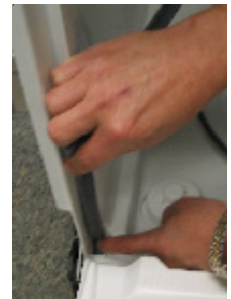

5. Form gasket into an "L" press gasket up channel in several spots.
6. Repeat steps 4 and 5 for opposite side
7. Close door to seat seal.



## UPPER RACK

1. **To remove rack, unsnap and remove retainers at end of metal track. Once retainers are removed, pull rack straight out.**
2. Each track roller is secured with a T-25 TORX bolt. When reinstalling the roller care must be taken not to cross thread the screw opening in tub.

## CENTER SPRAY ARM (PRECISION DIRECT MODELS)

1. Pull upper rack forward to gain access to spray arm.
2. **Center spray arm and delivery tube are an assembly, push this assembly to the rear to loosen and remove from rack.**

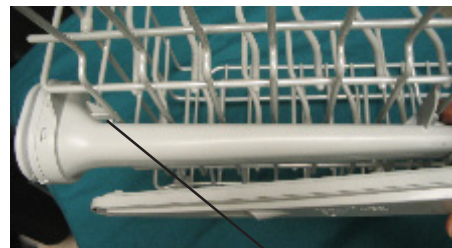

Retainer on rear of center  
arm delivery tube

## HEATING ELEMENT

1. Disconnect the dishwasher from electrical supply
2. To remove element disconnect wiring and remove two element mounting nuts.
3. Lift terminal ends from tub.
4. **Raise locking hook on mounting brackets to slide element from brackets.**

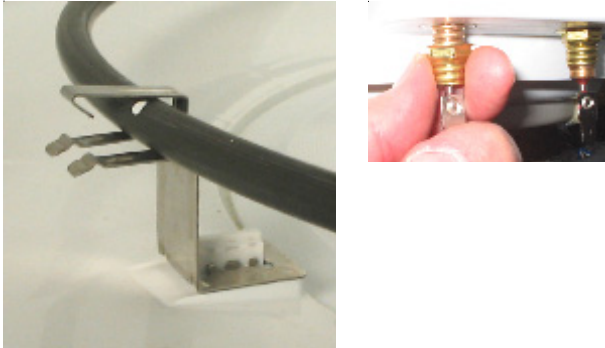

## FLOAT SWITCH AND MOUNT BRACKET

1. Disconnect the dishwasher from electrical supply
2. For ease of service remove outer door panel and kick plate, remove wires to float switch.
3. **Unscrew Phillips screw holding assembly to tub, there is a hole provided in the actuator lever to access screw. Screw will remain in assembly once removed.**

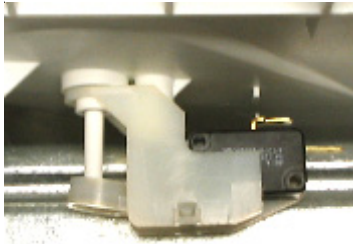

## WATER VALVE

1. Disconnect the dishwasher from electrical supply
2. Turn water off to dishwasher before replacing valve
3. Gain access to valve remove wiring, water line, and fitting from valve.
4. **Water valve is secured with two screws.**

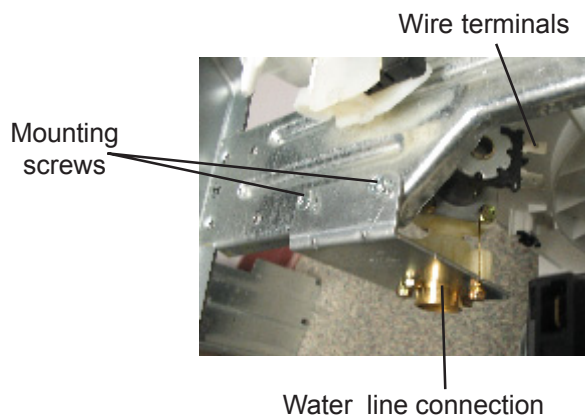

## DRAIN PUMP

### *Precision Wash*

1. Disconnect the dishwasher from electrical supply
2. Gain access to drain pump remove wiring and hoses from pump. Dishwasher may need to be pulled forward to access drain pump.
3. Pump is mounted with two screws through mounting bracket.

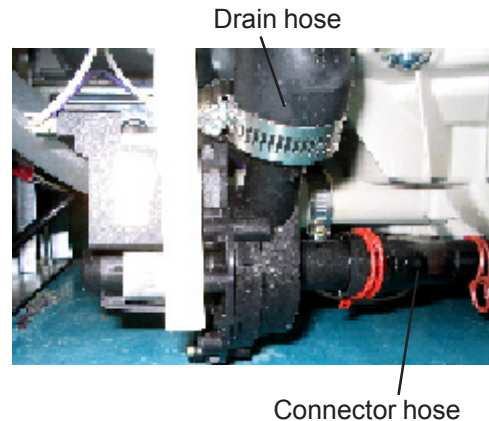

### *Precision Direct Wash System.*

1. Disconnect the dishwasher from electrical supply
2. Gain access to drain pump remove wiring and drain hose from pump. Slide clamp on hose between pump and sump to the center of hose

**NOTE:** When removing the drain pump, the hose clamp on the connector hose from the drain pump to the sump, it is recommended to slide the clamp back on the sump end of the hose. This will make it easier to reinstall the new drain pump.



3. Insert small screwdriver into top hole of pump mount on front of sump, push down on screw driver to release top mounting hook pull top of pump back and hold.

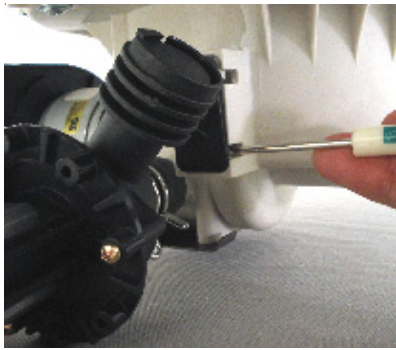

4. Insert screwdriver this timer in lower hole in pump mount, push down and pull back on pump will release pump from sump.
5. Pump can now be removed.



## DELIVERY TUBE.

**NOTE:** To remove Delivery tube, from either the Precision or Precision Direct Wash system models, the dishwasher will need to be removed from under counter top.

### ***Precision Wash***

1. With dishwasher removed from under counter top unscrew and remove nozzle in top of tub holding tube in place. Nozzle unscrews counter clockwise.
2. Loosen clamp on sump and remove tube.

### ***Precision Direct Wash System***

1. With dishwasher removed from under counter top unscrew and remove shower nozzle in top of tub. Nozzle unscrews counter clockwise.



2. Remove mounting screw in back of tub.



3. Remove clamp from sump end and remove tube.



4. To install tube start by placing tube in top of tub and installing shower nozzle loosely.
5. Place center opening in tub and installing screw make sure tube is snug in tub grommet before installing screw
6. Install tube onto sump and tighten clamp.
7. Return and reseal the top of the tube and tighten shower nozzle.



## PUMP AND MOTOR ASSEMBLY

### ***Precision Wash***

1. Disconnect the dishwasher from electrical supply
2. Remove spray arm, spray arm support, and filters from inside of tub.
3. Remove outer door panel and kick plate to gain access to underside of dishwasher.



4. Disconnect delivery tube and sump drain hose.

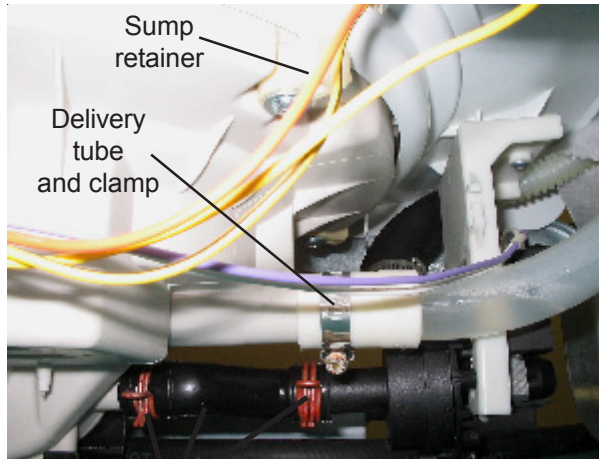

Hose from sump to drain pump with clamps

5. Pump and motor assembly is secured in place using four retainers that will turn into sump to release from tub. Lift assembly into tub.
6. Remove wires from motor.

### **Precision Direct Wash System**

1. Disconnect the dishwasher from electrical supply
2. Remove spray arm, spray arm support, and filters from inside of tub
3. Remove outer door panel and kick plate to gain access to the underside of the dishwasher.
4. Disconnect wires from both wash motor and drain pump, then remove the clamp from the delivery tube, this clamp can be accessed going back the right side of the sump. The clamp on the delivery tube has a 1/4 inch head. Carefully push delivery tube off rear port of the sump.

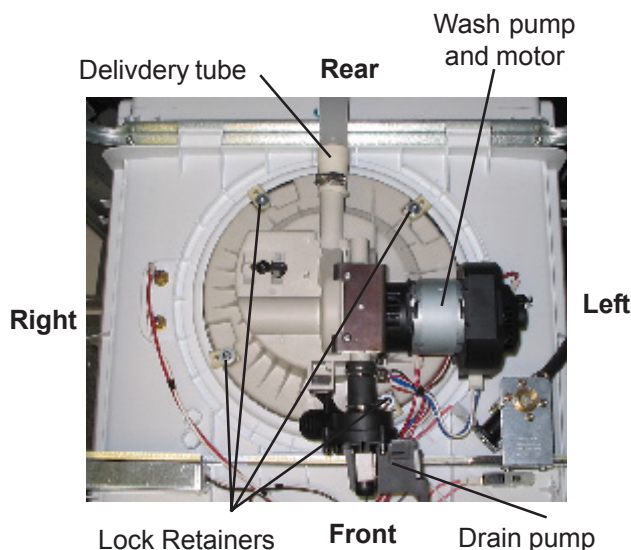

5. Pump and motor assembly is secured in place using four retainers that will turn into sump to release from tub. Push sump into tub, then by rotating to the right will aid in clearing wash pump and drain pump as sump is lifted out



Lift sump to the 2:00 position to remove

### **Remove motor from sump.**

1. Remove sump from tub
2. Remove volute cover and check ball
3. Turn sump over and remove motor mounting bracket (2 screws)
4. Lift bracket from sump.
5. Return sump to up right position.
6. Place end of a flat blade screwdriver in front of wash impeller and force motor out rear of sump.

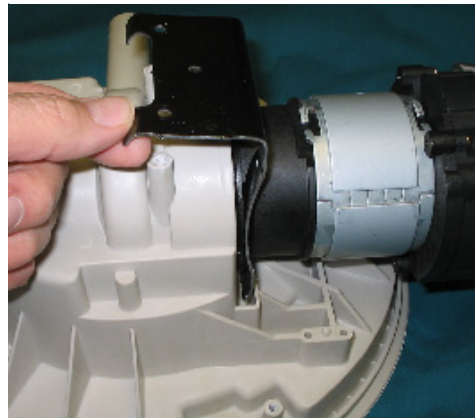

Removing mounting bracket



Forcing motor from sump

## TROUBLE SHOOTING TIPS

SYMPTOM	CHECK THE FOLLOWING	REMEDY
Dishwasher will not operate when turned on (no lights).	<ol style="list-style-type: none"> <li>1 Check for blown fuse or tripped breaker</li> <li>2 Power at junction box and power leads to dishwasher.</li> <li>3 Check disconnect block at control</li> </ol>	<ol style="list-style-type: none"> <li>1 Replace fuse or reset breaker</li> <li>2 Repair or replace wire connector as needed.</li> <li>5 Unplug disconnect block and reconnect making sure block is lock together properly</li> </ol>
Dishwasher will not operate when turned on (lights on).	<ol style="list-style-type: none"> <li>1 Check power at door switch</li> <li>2 Make sure door switches are being closed by door latch</li> </ol> <p style="text-align: center;"><b>Run Water Service Test on dishwasher to verify control and component operation</b></p> <ol style="list-style-type: none"> <li>3 Check disconnect block at control</li> <li>4 Check power at black wire from door switch to control disconnect (pin location 3)</li> </ol>	<ol style="list-style-type: none"> <li>1 Repair or replace wire connector as needed.</li> <li>2 Adjust or replace door latch</li> <li>3 Unplug disconnect block and reconnect making sure block is lock together properly</li> <li>4 Repair or replace terminal or replace door latch assembly</li> </ol>
Dishwasher not draining	<ol style="list-style-type: none"> <li>1 Check filter and sump</li> <li>2 Drain hose kinked</li> <li>3 Drain pump not running</li> </ol> <p style="text-align: center;"><b>Run Water Service Test on dishwasher to verify control and component operation</b></p>	<ol style="list-style-type: none"> <li>1 Clean filter</li> <li>2 Reroute drain hose</li> <li>3 See Symptom Drain pump not running dishwasher not draining.</li> </ol>
Drain pump will not run or dishwasher is not	<ol style="list-style-type: none"> <li>1 Drain pump is not running check for power to drain pump, this can be done at pump or at control disconnect (pin location 8)</li> <li>2 No power to drain pump</li> <li>3 Locked up pump impeller</li> <li>4 Broken or loose wire</li> </ol>	<ol style="list-style-type: none"> <li>1 Check resistance of motor windings (25ohms). No reading replace pump</li> <li>2 Replace control</li> <li>3 Check and remove blockage</li> <li>4 Repair or replace wire or connector</li> </ol>
Will not fill	<ol style="list-style-type: none"> <li>1 Check for water to dishwasher</li> <li>2 Check for water at valve</li> </ol> <p style="text-align: center;"><b>Run Water Service Test on dishwasher to verify control and component operation</b></p> <ol style="list-style-type: none"> <li>3 Check for power to water valve at float switch, switch open</li> <li>4 Broken or loose wire at water valve or float switch</li> <li>5 No power to float switch</li> <li>6 Open coil on water valve or stuck valve</li> </ol>	<ol style="list-style-type: none"> <li>1 Turn on water</li> <li>2 Clean screen in water valve</li> <li>3 Replace float switch assembly</li> <li>4 Repair or replace wire or connector</li> <li>5 Replace control</li> <li>6 Replace water valve</li> </ol>
Wash motor not running	<ol style="list-style-type: none"> <li>1 Wash impeller is stuck or blocked</li> </ol> <p style="text-align: center;"><b>Run Water Service Test on dishwasher to verify control and component operation</b></p> <ol style="list-style-type: none"> <li>2 No power to motor ( Pin location 12 at control)</li> <li>3 Broken or loose wire</li> <li>4 Lock up motor</li> </ol>	<ol style="list-style-type: none"> <li>1 Remove blockage</li> <li>2 Replace control</li> <li>3 Repair or replace wire or connector</li> <li>4 Replace motor</li> </ol>

SYMPTOM	CHECK THE FOLLOWING	REMEDY
Dishwasher runs but will not heat	<p><b>Run Water Service Test on dishwasher to verify control and component operation</b></p> <ul style="list-style-type: none"> <li>1 Hi- limit thermostat open</li> <li>2 Heating element open</li> <li>3 Broken or loose wire</li> <li>4 No power to Hi- limit thermostat</li> </ul>	<ul style="list-style-type: none"> <li>1 Replace Thermostat</li> <li>2 Replace Heater</li> <li>3 Repair or replace wire or connector</li> <li>4 Replace control</li> </ul>
Water in dishwasher not getting hot or staying hot	<ul style="list-style-type: none"> <li>1 Check incoming water temperature needs to be 120°F before starting cycle</li> <li>2 Check thermostat (10,000 ohms at 77° temperature)</li> <li>3 No power to heater Hi- limit thermostat open</li> <li>4 Broken or loose wire</li> <li>5 No power from control</li> </ul>	<ul style="list-style-type: none"> <li>1 Instruct customer</li> <li>2 Replace thermostat</li> <li>3 Replace Hi- limit thermostat</li> <li>4 Repair or replace wire or connector</li> <li>5 Replace control</li> </ul>
Detergent dispenser will not open	<ul style="list-style-type: none"> <li>1 Check latch on Dispenser door</li> </ul> <p><b>Run Water Service Test on dishwasher to verify control and component operation</b></p> <ul style="list-style-type: none"> <li>2 Power to dispenser</li> <li>3 Broken or loose wire</li> <li>4 No power to dispenser</li> </ul>	<ul style="list-style-type: none"> <li>1 Clean latch on dispenser</li> <li>2 Replace detergent dispenser</li> <li>3 Repair or replace wire or connector</li> <li>4 Replace control</li> </ul>
Dishes not clean	<ul style="list-style-type: none"> <li>1 Check water temperature</li> <li>2 Check water hardness Check water level in tub 1.2 gallons needed</li> <li>3 Racks not loaded properly</li> <li>4 Spray arm not turning free</li> <li>5 Check filter</li> </ul>	<p>Water needs to be 120°F before starting cycle</p> <p>Water hardness determents how much detergent is needed See not filling section to locate problem</p> <ul style="list-style-type: none"> <li>4 Instruct user in proper loading Spray arm warped or bowed replace arm</li> <li>5 arm</li> <li>6 Clean or replace filter</li> </ul>
Dishes not dry	<ul style="list-style-type: none"> <li>1 Heated dry option selected</li> <li>2 Check water temperature</li> <li>3 Check for presence of rinse aid</li> <li>4 Racks not loaded properly</li> <li>5 Heater not heating</li> </ul>	<ul style="list-style-type: none"> <li>1 Select option Water needs to be 120°F before starting cycle</li> <li>2 starting cycle</li> <li>3 Fill dispenser and increase setting</li> <li>4 Instruct user in proper loading See Section <b>Dishwasher runs but will not heat</b></li> <li>5 <b>will not heat</b></li> </ul>
Detergent is left in dispenser	<ul style="list-style-type: none"> <li>1 Check water temperature</li> <li>2 Does dispenser open Check detergent to see if it has caked in box</li> <li>3 Has dispenser dry before adding detergent</li> </ul>	<ul style="list-style-type: none"> <li>1 Incoming water needs to be 120°F See Section <b>Detergent dispenser will not open</b></li> <li>2 <b>will not open</b></li> <li>3 Replace detergent</li> <li>4 Instruct user in use of detergent</li> </ul>

## TECHNICAL SPECIFICATIONS

<b>PRECISION SELECT MODEL</b>		
<b>MODEL</b>	<b>FDB1250RE</b>	<b>FDB1050RE</b>
<b>ELECTRICAL</b>		
<b>SERVICE DATA SHEET</b>	154547801	154547901
Voltage	120VAC	120VAC
Cycles	60 Hertz	60 Hertz
Circuit Rating (Amps)	15 /20	15 /20
Motor (HP)		
Motor (Amps)	0.6	0.6
Heater (Watts)	900	900
Total Amps	10.0	10.0
Temp Assure	140°F ±5°F	140°F ±5°F
Temp Boost	145°F ±5°F	145°F ±5°F
Sanitize	155°F ±5°F	
Hi-Limit Thermostat	200°F	200°F
<b>COMPONENT RESISTANCE (ohms)</b>		
Heater Element	9.28	9.28
Pump motor	N/A	N/A
Vent Actuator	N/A	N/A
Dispenser	1928	1928
Drain Motor	28	28
Water Valve Solenoid	699	699
<b>WATER SUPPLY</b>		
Minimum Incoming Water Temperature	120°F	120°F
Pressure (min/max - psi)	20 / 120	20 / 120
Connection (NPT)	3/8"	3/8"
Normal Cycle Water Consumption (gal)	4.9 - 9.7	4.9 - 9.7
Water Valve Flow Rate (GPM)	0.83	0.83
Water Recirculation Rate (GPM)	approx.12	approx.12
Water Fill Time (Seconds)	87	87

# EXPLODED VIEW DIAGRAMS

## Model FDB1050RE

Control Panel .....	A2
Door .....	A3
Tub .....	A4
Motor & Pump .....	A5
Frame .....	A6
Racks .....	A7

## Model FDB1250RE

Control Panel .....	A8
Door .....	A9
Tub .....	A10
Motor & Pump .....	A11
Frame .....	A6
Racks .....	A12

# CONTROL PANEL FOR FDB1050RE

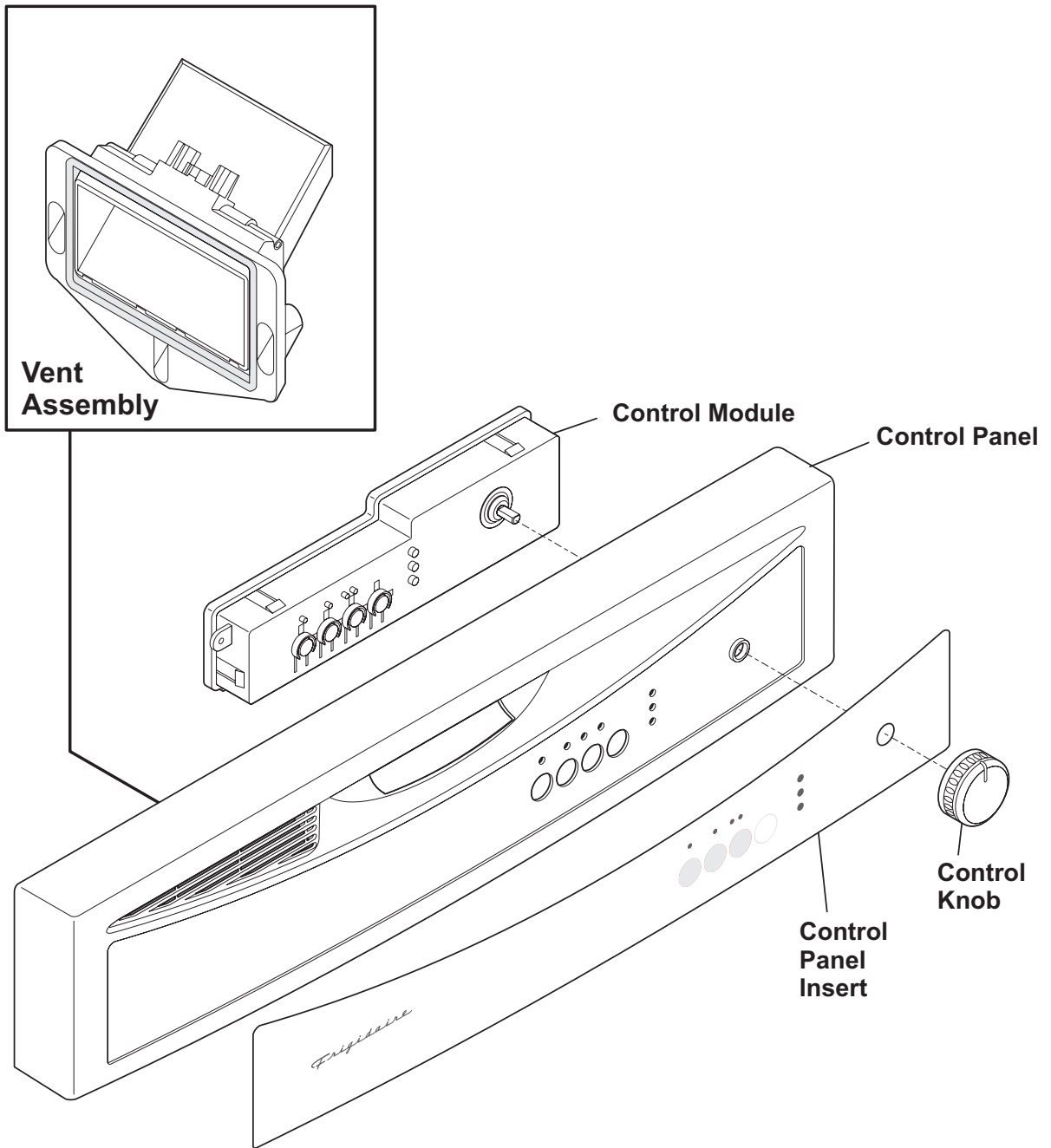

# DOOR FOR FDB1050RE

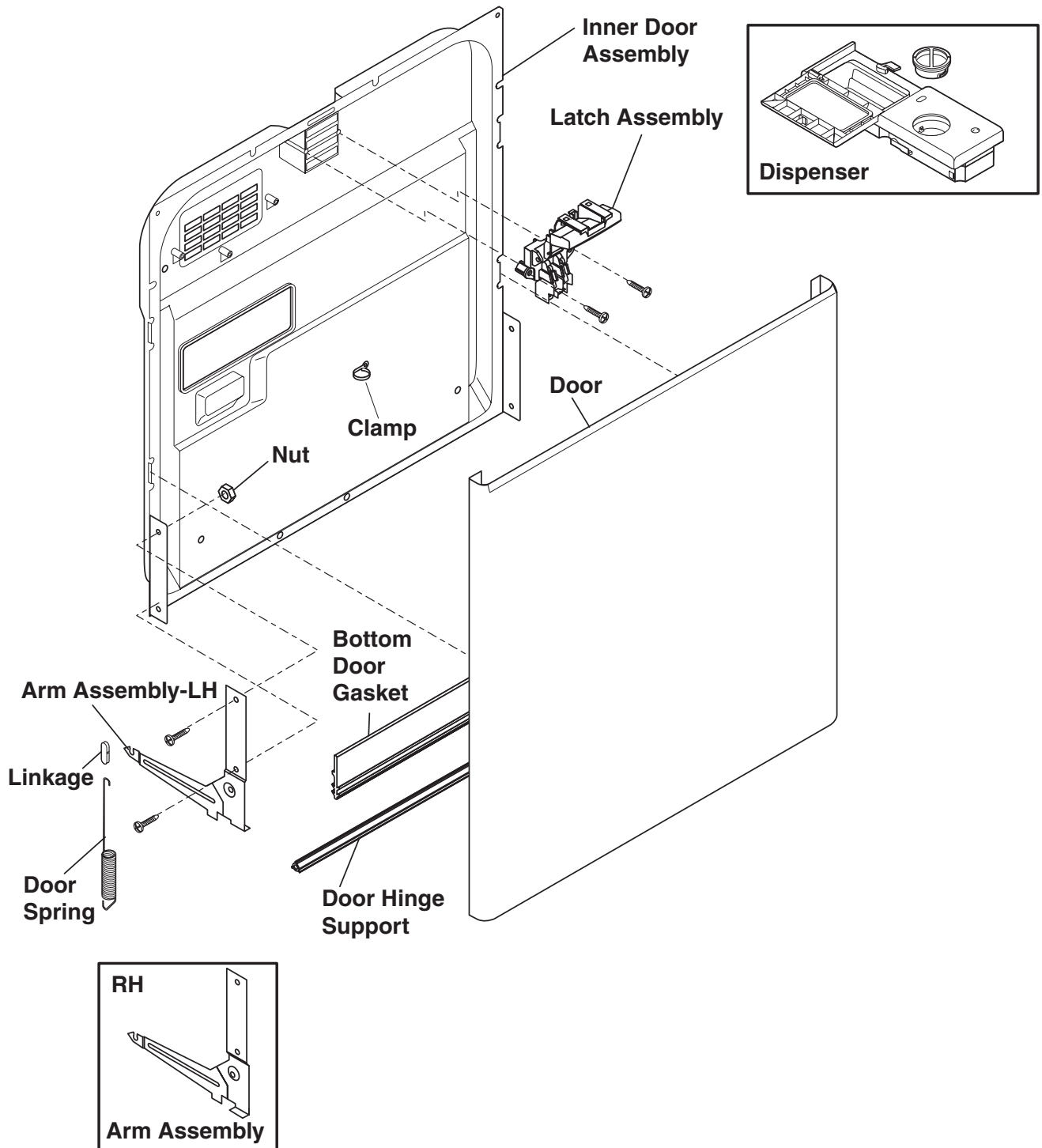

# TUB FOR FDB1050RE

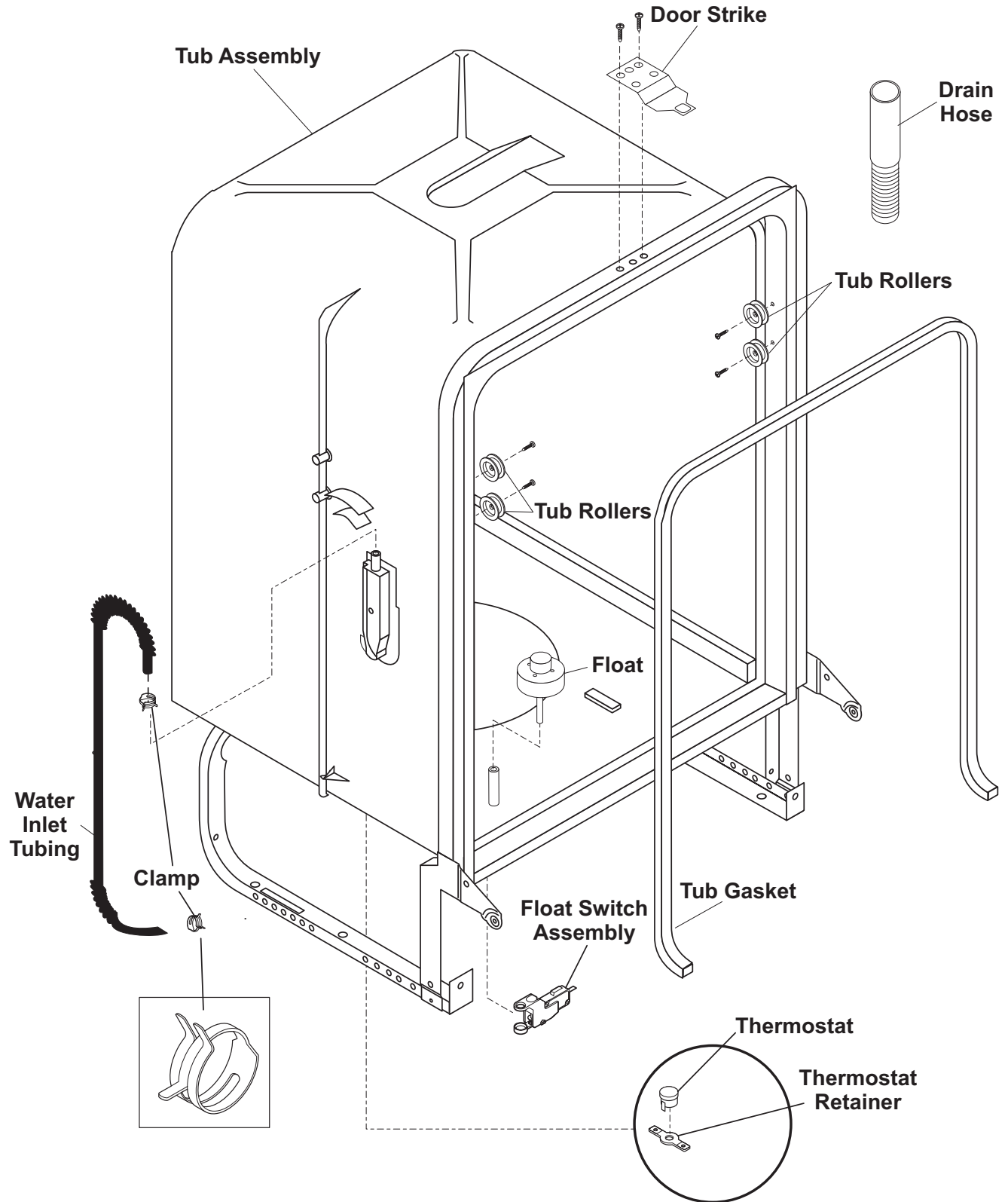



# MOTOR & PUMP FOR FDB1050RE

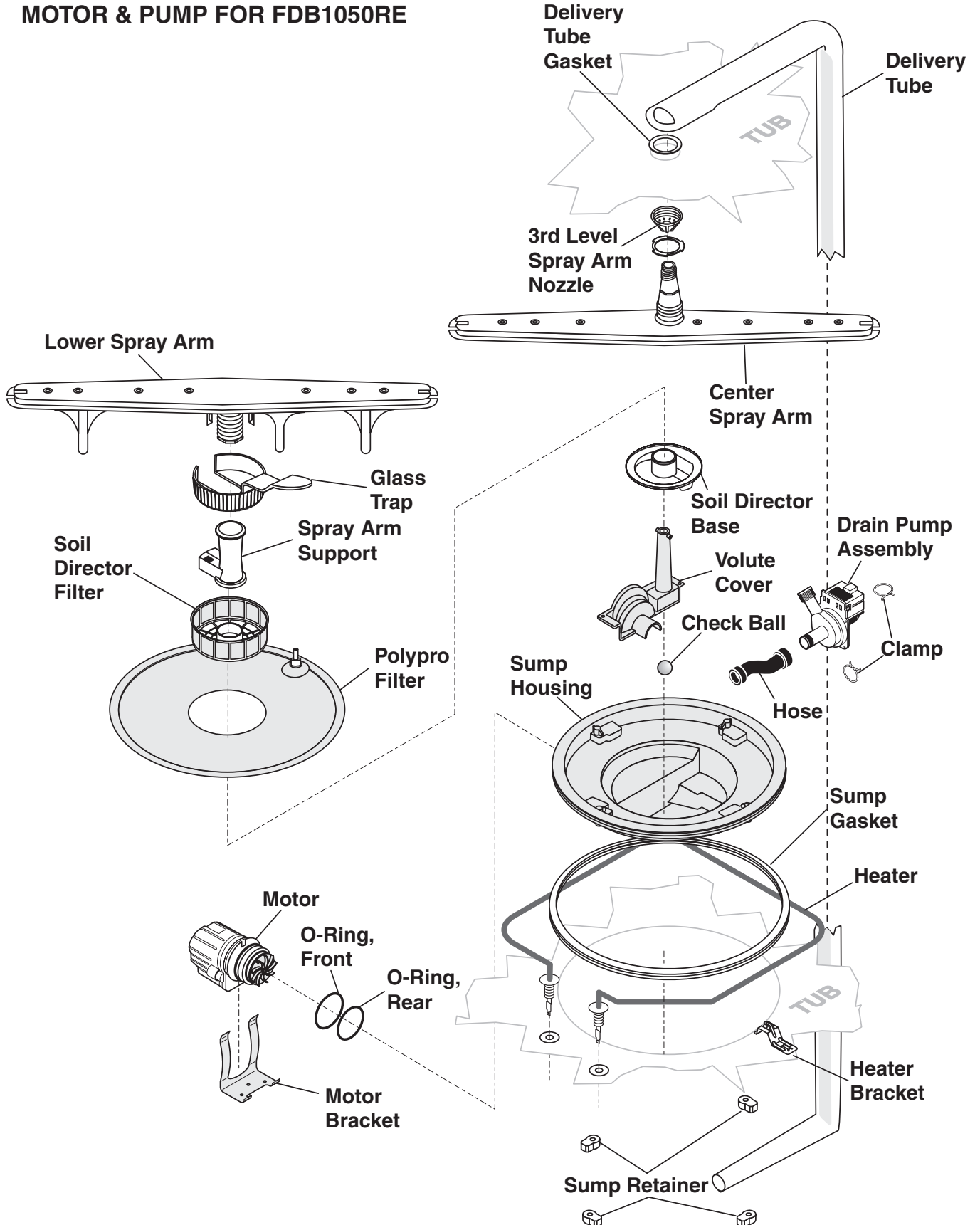

**FRAME FOR FDB1050RE & FDB1250RE**

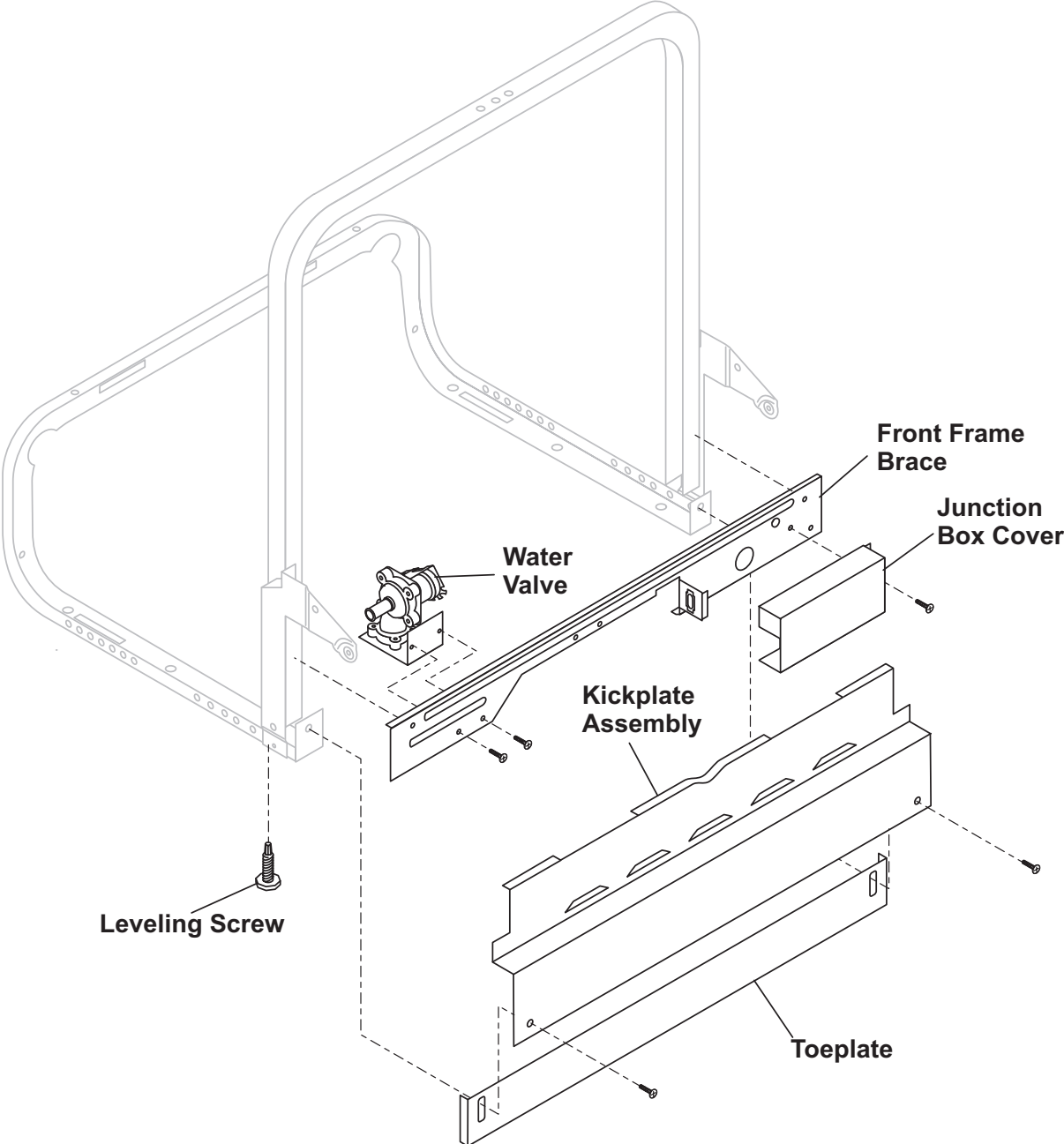

# RACKS FOR FDB1050RE

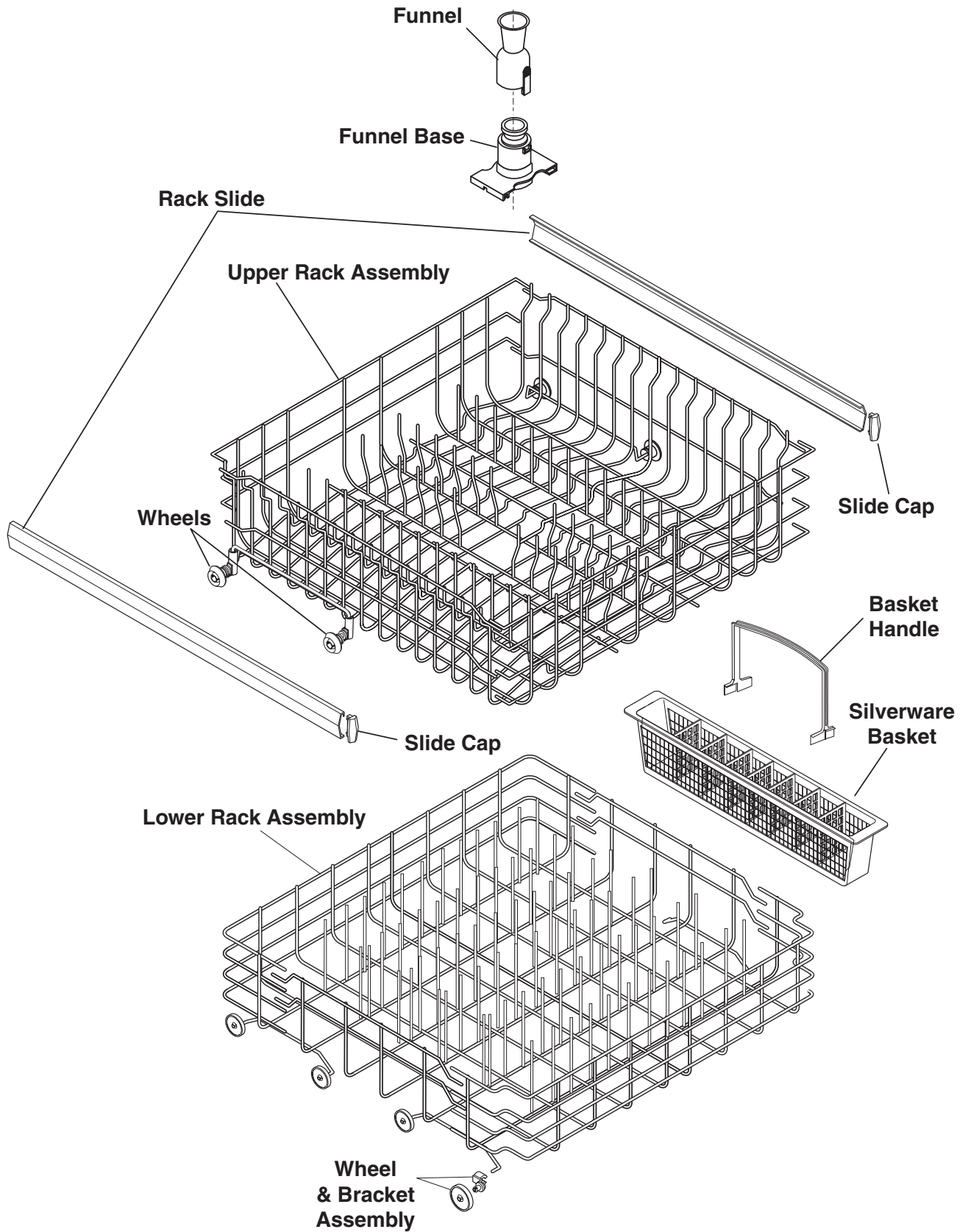

# CONTROL PANEL FOR FDB1250RE

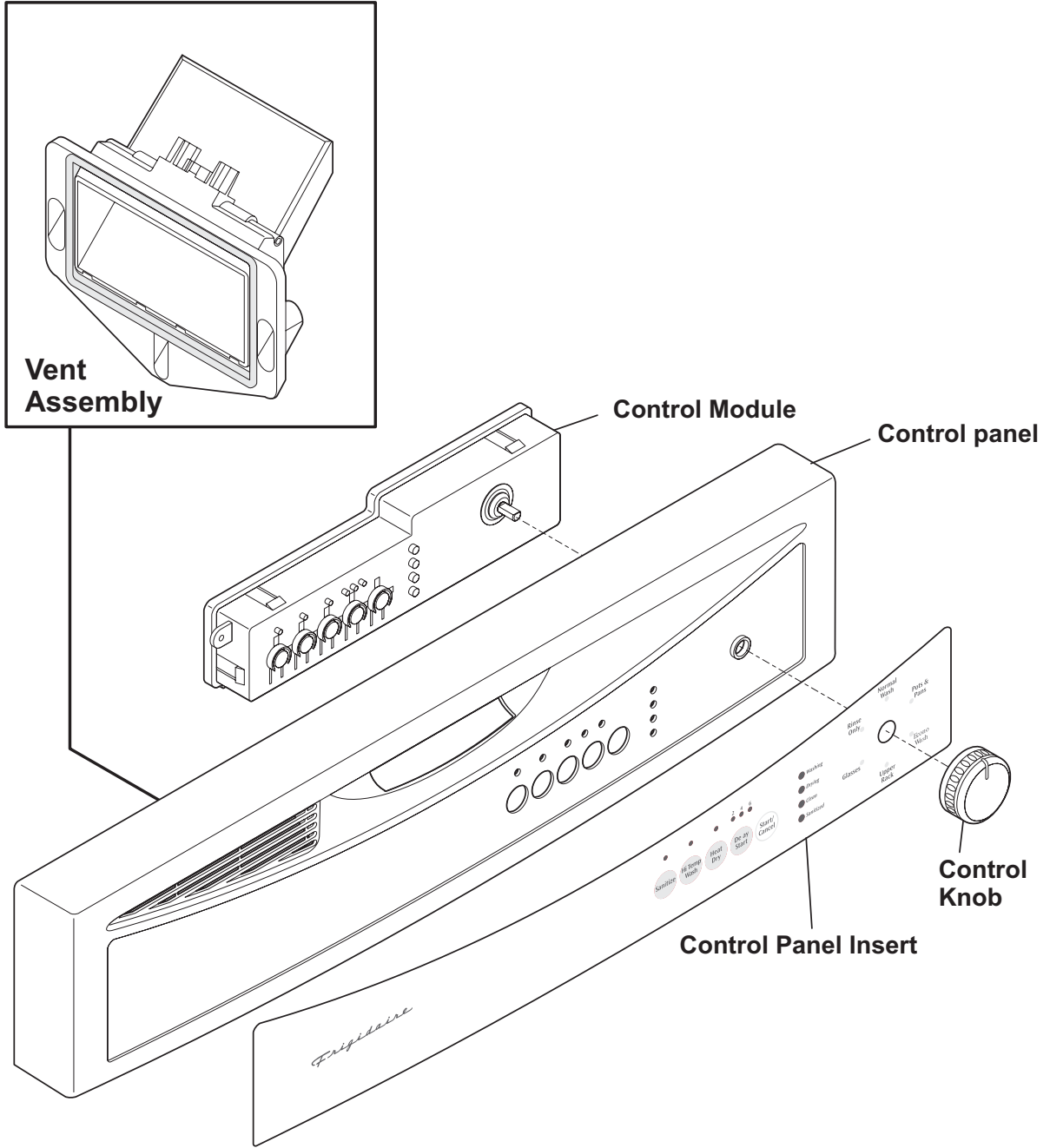

# DOOR FOR FDB1250RE

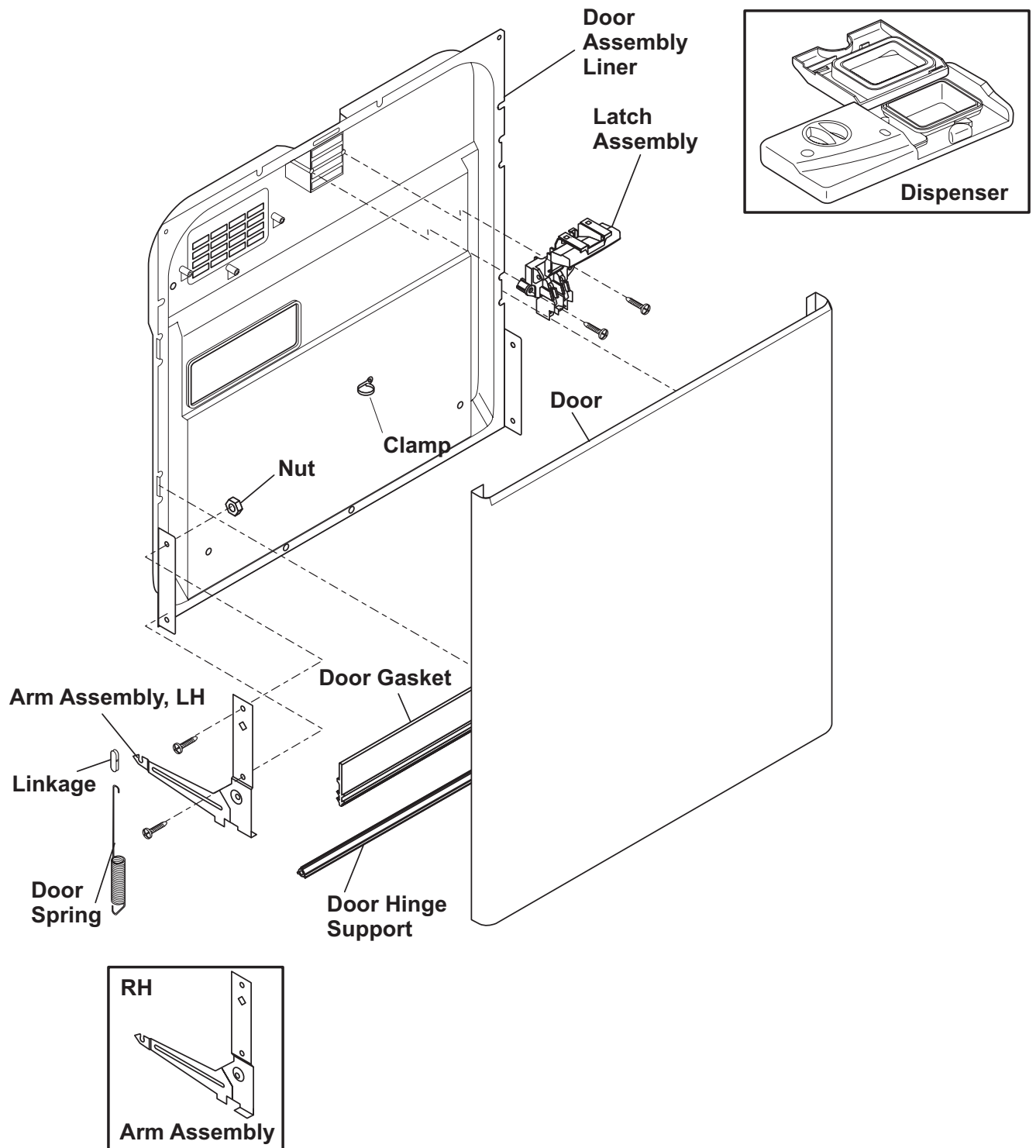

# TUB FOR FDB1250RE

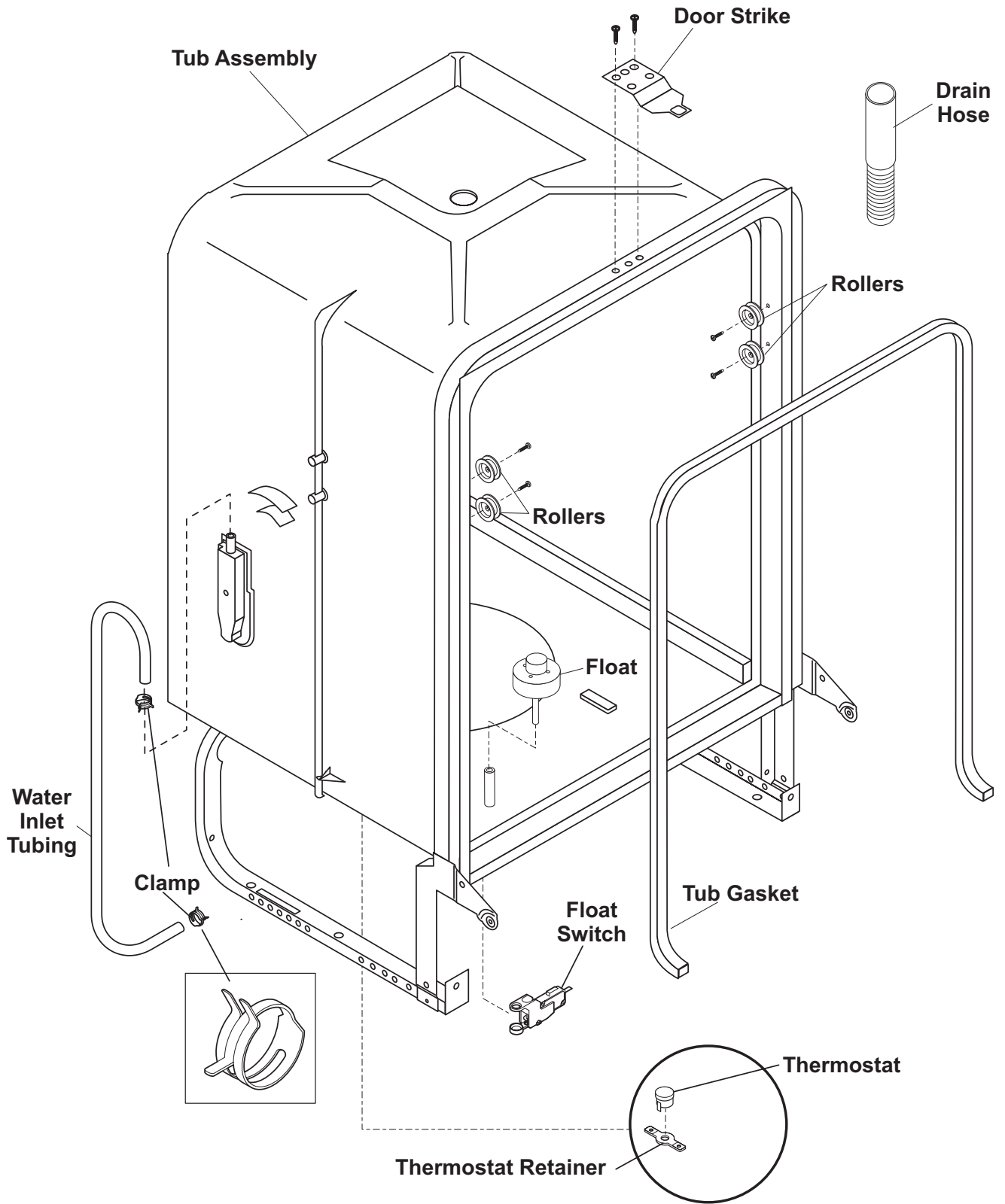

# MOTOR & PUMP FOR FDB1250RE

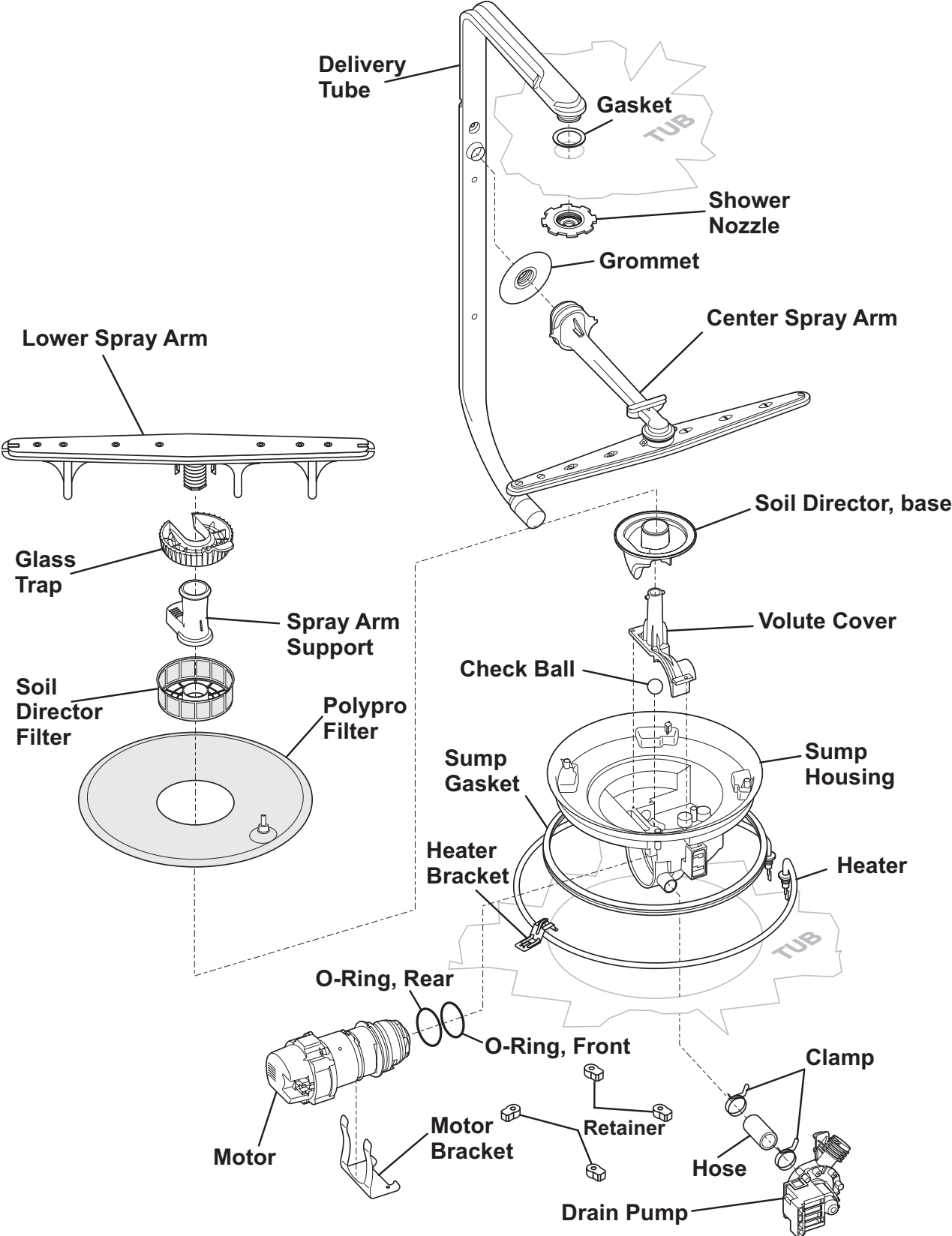

# RACK FOR FDB1250RE

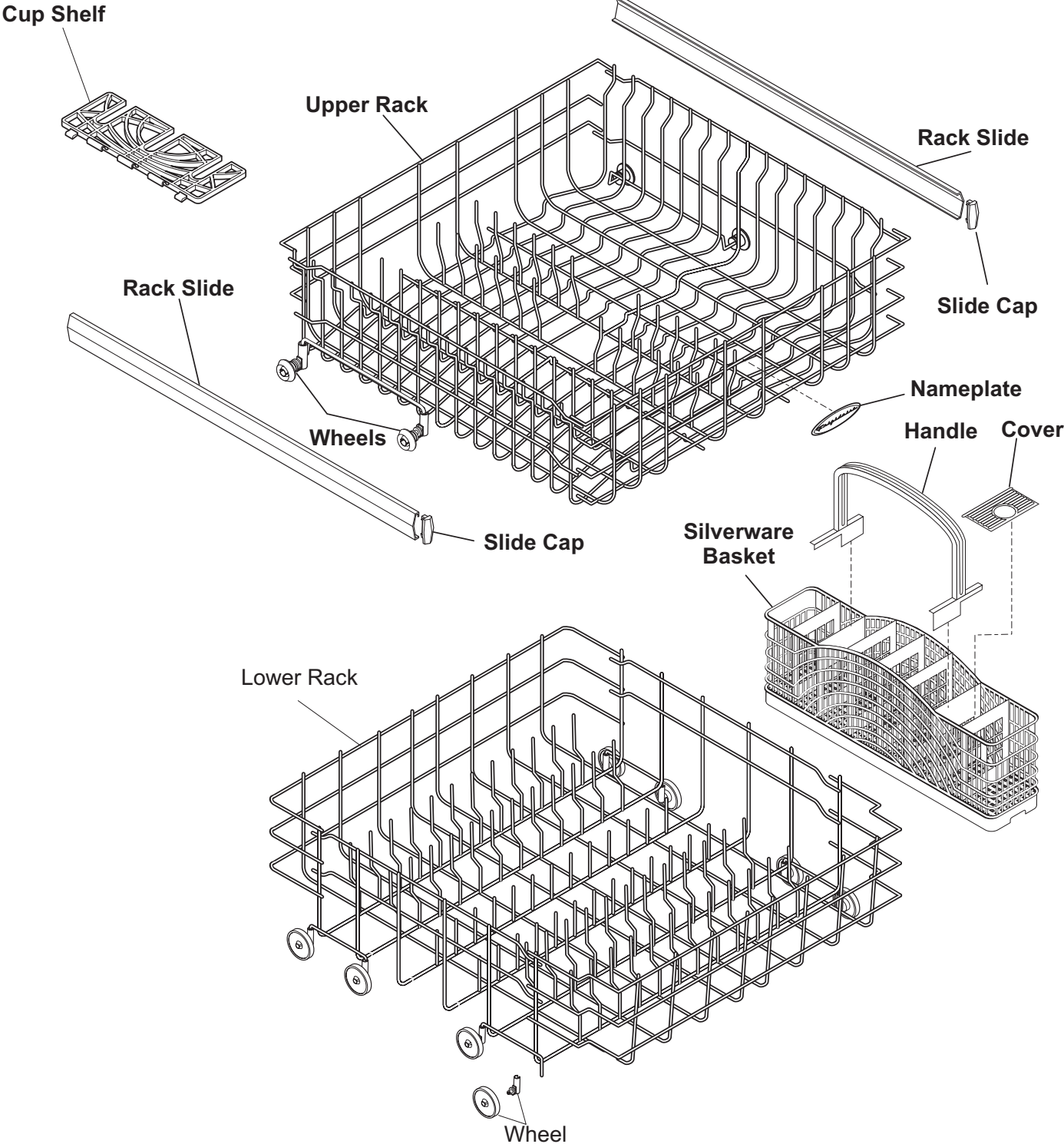



P/N: 154547801

# Frigidaire

## Electronic Series

This information is intended for use by persons having electrical and mechanical training and a level of knowledge of these subjects generally considered acceptable in the appliance repair trade. Electrolux Major Appliances North America cannot be responsible, nor assume any liability, for injury or damage of any kind arising from the use of this Service Data Sheet.

### Color Code

BK.....Black  
 BU.....Blue  
 PK.....Pink  
 R.....Red  
 R-BK.....Red/Black  
 R-Y.....Red/Yellow  
 VIO.....Violet  
 W.....White

### Operation

**To start** . . . . . Close and latch door. Press START/CANCEL pad.  
**To delay start** . . . . . Close and latch door. Press DELAY START pad to select desired delay time.  
**To select a new cycle or option** . . . . . Press desired cycle and/or option pad. The indicator lights will change. Press START/CANCEL within 15 seconds to begin cycle.  
**To cancel cycle** . . . . . Press START/CANCEL. Dishwasher will drain for 90 seconds, then shut off.

### ⚠ WARNING

Disconnect electrical power at the fuse box or circuit breaker box before servicing under this product. Electrical power may be present on some parts under this product, even if not in use.

Failure to follow this warning could result in serious injury or death.

### Display Codes (LED)

**WASHING** ----- Wash portion of cycle.  
**SANITIZED** ----- The SANITIZED criteria has been met. Indicator light will switch off when door is opened.  
**DRYING** ----- Drying portion of cycle.  
**CLEAN** ----- Shows completion of cycle. Indicator light will switch off when door is opened.  
**OPTION LED's Flashing** -- All LED's flashing indicates power failure has occurred. Press START/CANCEL pad and reselect desired options and cycle.  
**STATUS LED's Flashing** -- The STATUS LED's that are lit when the door is opened will flash. Close door.

### Water/Service Test

The water/service test is a special function initiated from the power failure mode or idle mode.

While in power failure mode - simultaneously press the HEAT DRY and START/CANCEL pads for 1/2 second, with the selector dial set to RINSE ONLY.

The dishwasher will then step through the test cycle per the chart. Pushing the START/CANCEL pad will advance the dishwasher to the next step.

While in idle mode - simultaneously press the HEAT DRY and START/CANCEL pads for 3 seconds, with the selector dial set to RINSE ONLY.

STEP		TOTAL TIME (SEC)	WATER VALVE	CIRCULATION MOTOR	DRAIN MOTOR	HEATER	DISPENSER	VENT*	WASHING LED	SANITIZED LED	DRYING LED	CLEAN LED
1	FILL/DISPENSER	60	1	0	0	0	1	1	1	0	0	0
2	FILL	27	1	0	0	0	0	1	1	0	0	0
3	WASH	45	0	1	0	0	0	1	1	0	0	0
4	PAUSE	0.4	0	0	0	1	0	1	1	0	0	0
5	WASH/HEAT	75	0	1	0	1	0	1	0	0	0	0
6	WASH/HEAT/DISP.	60	0	1	0	1	1	1	0	0	0	0
7	DRAIN	90	0	0	1	0	0	1	0	0	0	0
8	DRY	90	0	0	1	X	0	0	0	1	0	0
	TOTAL	488							0	1	0	1

X - denotes selectable option  
 CLEAN LED stays on until door is opened or cycle is started.

### Wiring Diagram

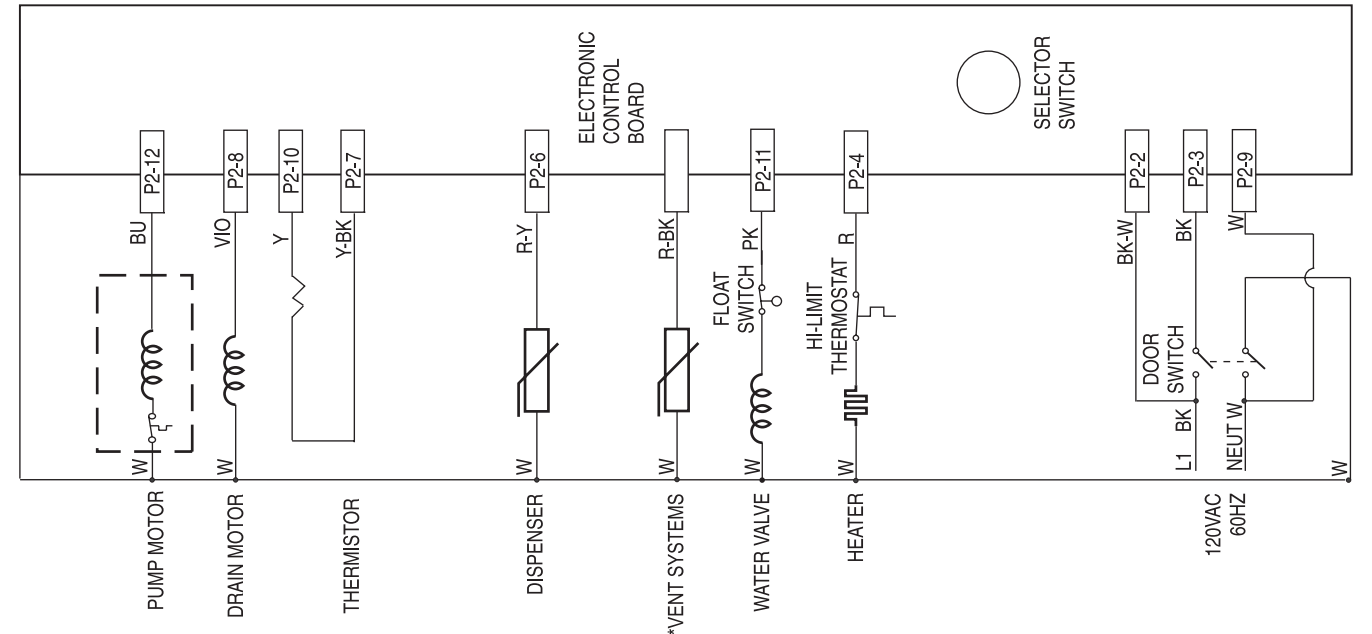

### Cycle Selection Options

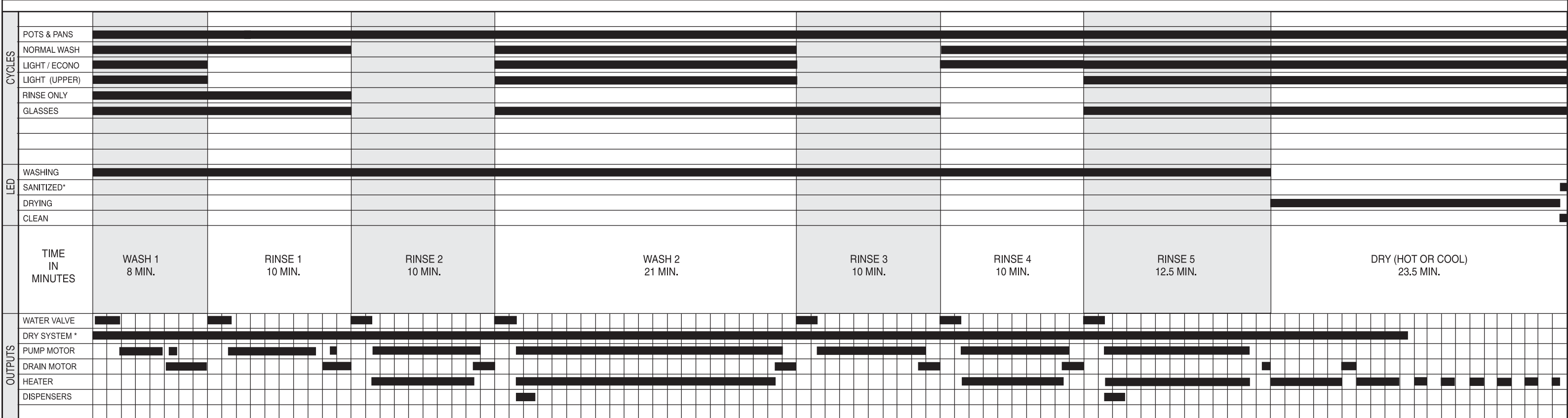

\* SOME MODELS

▲ WATER HEAT DELAY

▲ WATER HEAT DELAY

# Exploded View of Wash System

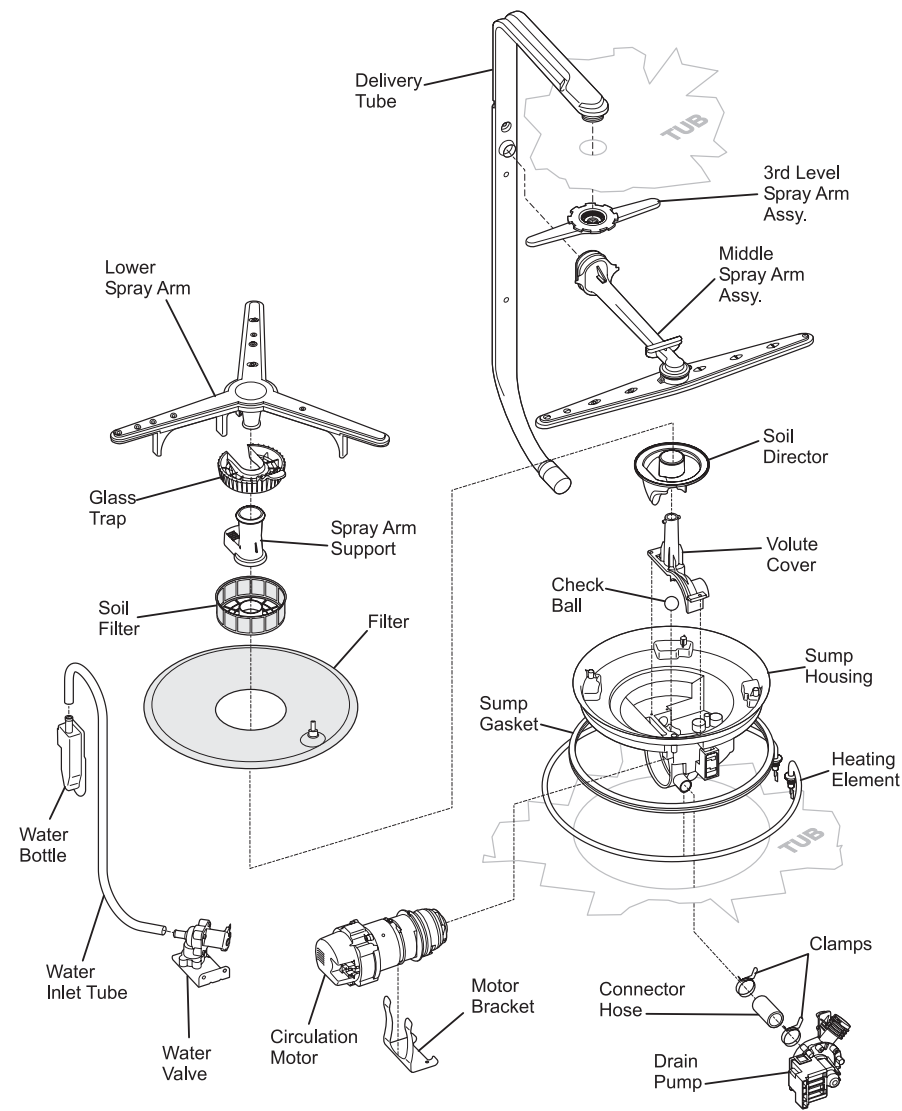

## Pump Assembly

The pump assembly is driven by a synchronous motor. Rotation is in the counterclockwise direction at 3600 RPM. The motor drives a pump which supplies 100 percent filtered water at a rate of approximately 12 GPM to one spray arm at a time. The spray arm's operation is alternated by small "pauses" of the motor during the wash cycle.

Draining is accomplished by using a small separate synchronous drain pump mounted to the side of the sump. The drain pump is connected to the main pump by a small rubber hose. The drain check valve is located at the discharge end of the drain pump. The drain hose

is attached by a worm gear clamp to the discharge end of the drain pump.

The drain hose must have a loop at a **minimum height of 32 inches** in order to insure proper drainage.

The main pump can easily be removed by disconnecting the upper spray arm supply tube hose, the drain pump connector hose, the wiring harness connections made at the circulation motor, the water heat thermistor located on the bottom of the pump and rotating the four sump retainers toward the middle of the sump.

## 900 Watt Heater

Refer to the cycle chart on the reverse side to determine when the heater is on during the wash cycle. The heater cycles **ON** and **OFF** for brief periods during the drying cycle.

Voltage checks of the heater should be made in the dry portion of the service test mode.

## Standard Dry Air Flow

When the control advances to the "dry" portion of the cycle, a linear actuator retracts a valve, which opens a vent path through the console into the kitchen. The heated, moist air leaving the dishwasher through the console vent causes drier air to be drawn into the unit by way of intake

vents located at the bottom of the door. The water on the dishes is evaporated into drier air and the venting process continues. The heating element is turned **ON** and **OFF** during the entire drying cycle.

## Detergent and Rinse Aid Dispenser

The detergent and rinse aid dispenser is a one piece component consisting of a molded detergent cup and a built-in rinse aid dispenser.

The detergent cup has a spring loaded cover and the rinse aid dispenser has a removable cover.

Liquid rinse aid is added to the dispenser up to the fill line indicator. The amount of rinse aid released can be adjusted by turning the arrow indicator from one, being the least amount, to four, being the greatest amount.

### To replace dispenser:

- shut off electricity to dishwasher,
- remove outer door panel assembly,
- disconnect wiring to the actuator,
- remove the six screws,
- remove the dispenser,
- replace and reinstall screws,
- rewire actuator.

## Tub and Door Seal

The door seal is pressed into the tub channel for an interference fit. Center the gasket (marked on back) at the tub top center and press in place

without stretching or bunching. The gasket takes a short turn at the bottom of the tub channel before ending at the channel end wall.

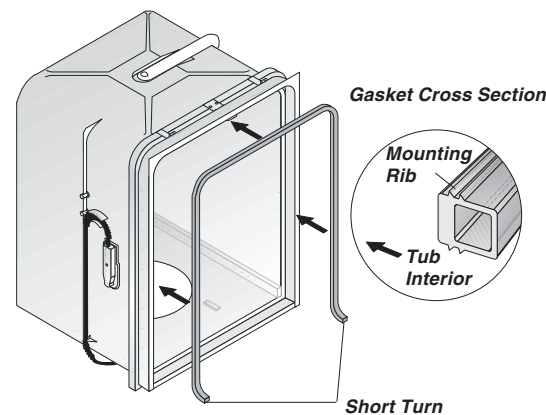

## Product Specifications

### Electrical

Rating .....	120 Volts, 60Hz
Separate Circuit..15 amp min.- 20 amp max.	
Motor (Amps) .....	0.6
Heater Wattage .....	900
Total Amps (load rated) .....	10.0
TempAssure .....	140°F ±5°F (60°C±3°C) [with outer door in place]
TempBoost.....	145°F ±5°F (63°C ±3°C)
	Heated Wash/Heated Rinse
Sanitize .....	155°F ±5°F (66°C ±3°C)
Hi-Limit Thermostat .....	200°F (93°C)

### Water Supply

Suggested minimum incoming water temperature .....	120°F (49°C)
Pressure (PSI) min./max. ....	20/120
Connection (NPT) .....	3/8"
Consumption (Normal Cycle) .....	4.9 - 9.7 U.S. gal., 18.5 - 36.7 liters
Water valve flow rate (U.S. GPM) .....	.83
Water recirculation rate (U.S. GPM) .....	approx. 12
Water fill time .....	87 sec.

# Trouble Shooting Tips

## ⚠ WARNING

### Personal Injury Hazard

Always disconnect the dishwasher from the electrical power source before adjusting or replacing components.

Symptom	Check the Following	Remedy
Dishwasher will not operate when turned on.	<ol style="list-style-type: none"> <li>1. Fuse (blown or tripped).</li> <li>2. 120 VAC supply wiring connection faulty.</li> <li>3. Electronic control board defective.</li> <li>4. Motor (inoperative).</li> <li>5. Door switch (open contacts).</li> <li>6. Door latch not making contact with door switch.</li> <li>7. Touch pad circuit defective.</li> <li>8. No indicator lamps illuminate when START or OPTIONS are pressed.</li> </ol>	<ol style="list-style-type: none"> <li>1. Replace fuse or reset breaker.</li> <li>2. Repair or replace wire fasteners at dishwasher junction box.</li> <li>3. Replace control module.</li> <li>4. Replace motor/impeller assembly.</li> <li>5. Replace latch assembly.</li> <li>6. Replace latch assembly.</li> <li>7. Replace console assembly.</li> <li>8. Replace console assembly.</li> </ol>
Motor hums but will not start or run.	<ol style="list-style-type: none"> <li>1. Motor (bad bearings).</li> <li>2. Motor stuck due to prolonged non-use.</li> </ol>	<ol style="list-style-type: none"> <li>1. Replace motor assembly.</li> <li>2. Rotate motor impeller.</li> </ol>
Motor trips out on internal thermal overload protector.	<ol style="list-style-type: none"> <li>1. Improper voltage.</li> <li>2. Motor windings shorted.</li> <li>3. Glass or foreign items in pump.</li> </ol>	<ol style="list-style-type: none"> <li>1. Check voltage.</li> <li>2. Replace motor/impeller assembly.</li> <li>3. Clean and clear blockage.</li> </ol>
Dishwasher runs but will not heat.	<ol style="list-style-type: none"> <li>1. Heater element (open).</li> <li>2. Electronic control board defective.</li> <li>3. Wiring or terminal defective.</li> <li>4. Hi-Limit thermostat defective.</li> </ol>	<ol style="list-style-type: none"> <li>1. Replace heater element.</li> <li>2. Replace control module.</li> <li>3. Repair or replace.</li> <li>4. Replace thermostat.</li> </ol>
Detergent cover will not latch or open.	<ol style="list-style-type: none"> <li>1. Latch mechanism defective.</li> <li>2. Electronic control board defective.</li> <li>3. Wiring or terminal defective.</li> <li>4. Broken spring(s).</li> <li>5. Defective actuator.</li> </ol>	<ol style="list-style-type: none"> <li>1. Replace dispenser.</li> <li>2. Replace control module.</li> <li>3. Repair or replace.</li> <li>4. Replace dispenser.</li> <li>5. Replace dispenser.</li> </ol>
Dishwasher will not pump out.	<ol style="list-style-type: none"> <li>1. Drain restricted.</li> <li>2. Electronic control board defective.</li> <li>3. Defective drain pump.</li> <li>4. Blocked impeller.</li> <li>5. Open windings.</li> <li>6. Wiring or terminal defective.</li> </ol>	<ol style="list-style-type: none"> <li>1. Clear restrictions.</li> <li>2. Replace control module.</li> <li>3. Replace pump.</li> <li>4. Check for blockage, clear.</li> <li>5. Replace pump assembly.</li> <li>6. Repair or replace.</li> </ol>
Dishwasher will not fill with water.	<ol style="list-style-type: none"> <li>1. Water supply turned off.</li> <li>2. Defective water inlet fill valve.</li> <li>3. Check fill valve screen for obstructions.</li> <li>4. Defective float switch.</li> <li>5. Electronic control board defective.</li> <li>6. Wiring or terminal defective.</li> <li>7. Float stuck in "UP" position.</li> </ol>	<ol style="list-style-type: none"> <li>1. Turn water supply on.</li> <li>2. Replace water inlet fill valve.</li> <li>3. Disassemble and clean screen.</li> <li>4. Repair or replace.</li> <li>5. Replace control module.</li> <li>6. Repair or replace.</li> <li>7. Clean float.</li> </ol>
Dishwasher water siphons out.	<ol style="list-style-type: none"> <li>1. Drain hose (high) loop too low.</li> <li>2. Drain line connected to a floor drain not vented.</li> </ol>	<ol style="list-style-type: none"> <li>1. Repair to proper <b>32-inch minimum height</b>.</li> <li>2. Install air gap at counter top.</li> </ol>
Detergent left in dispenser.	<ol style="list-style-type: none"> <li>1. Detergent allowed to stand too long in dispenser.</li> <li>2. Dispenser wet when detergent was added.</li> <li>3. Detergent cover held closed or blocked by large dishes.</li> <li>4. Improper incoming water temperature to properly dissolve detergent.</li> <li>5. See "Detergent cover will not open."</li> </ol>	<ol style="list-style-type: none"> <li>1. Instruct customer/user.</li> <li>2. Instruct customer/user.</li> <li>3. Instruct customer/user on proper loading of dishes.</li> <li>4. Incoming water temperature of 120°F is required to properly dissolve dishwashing detergents.</li> </ol>

P/N: 154547901

# Frigidaire

## Electronic Series

This information is intended for use by persons having electrical and mechanical training and a level of knowledge of these subjects generally considered acceptable in the appliance repair trade. Electrolux Major Appliances North America cannot be responsible, nor assume any liability, for injury or damage of any kind arising from the use of this Service Data Sheet.

### Color Code

BK.....Black  
 BU.....Blue  
 PK.....Pink  
 R.....Red  
 R-BK.....Red/Black  
 R-Y.....Red/Yellow  
 VIO.....Violet  
 W.....White

### Operation

**To start** . . . . . Close and latch door. Press START/CANCEL pad.  
**To delay start** . . . . . Close and latch door. Press DELAY START pad to select desired delay time.  
**To select a new cycle or option** . . . . . Press desired cycle and/or option pad. The indicator lights will change. Press START/CANCEL within 15 seconds to begin cycle.  
**To cancel cycle** . . . . . Press START/CANCEL. Dishwasher will drain for 90 seconds, then shut off.

### ⚠ WARNING

Disconnect electrical power at the fuse box or circuit breaker box before servicing under this product. Electrical power may be present on some parts under this product, even if not in use.  
 Failure to follow this warning could result in serious injury or death.

### Display Codes (LED)

**WASHING** ----- Wash portion of cycle.  
**SANITIZED** ----- The SANITIZED criteria has been met. Indicator light will switch off when door is opened.  
**DRYING** ----- Drying portion of cycle.  
**CLEAN** ----- Shows completion of cycle. Indicator light will switch off when door is opened.  
**OPTION LED's Flashing** -- All LED's flashing indicates power failure has occurred. Press START/CANCEL pad and reselect desired options and cycle.  
**STATUS LED's Flashing** -- The STATUS LED's that are lit when the door is opened will flash. Close door.

### Water/Service Test

The water/service test is a special function initiated from the power failure mode or idle mode.

While in power failure mode - simultaneously press the HEAT DRY and START/CANCEL pads for 1/2 second, with the selector dial set to RINSE ONLY.  
 The dishwasher will then step through the test cycle per the chart. Pushing the START/CANCEL pad will advance the dishwasher to the next step.

While in idle mode - simultaneously press the HEAT DRY and START/CANCEL pads for 3 seconds, with the selector dial set to RINSE ONLY.

STEP		TOTAL TIME (SEC)	WATER VALVE	CIRCULATION MOTOR	DRAIN MOTOR	HEATER	DISPENSER	VENT*	WASHING LED	SANITIZED LED	DRYING LED	CLEAN LED
1	FILL/DISPENSER	60	1	0	0	0	1	1	1	0	0	0
2	FILL	27	1	0	0	0	0	1	1	0	0	0
3	WASH	45	0	1	0	0	0	1	1	0	0	0
4	PAUSE	0.4	0	0	0	1	0	1	1	0	0	0
5	WASH/HEAT	75	0	1	0	1	0	1	0	0	0	0
6	WASH/HEAT/DISP.	60	0	1	0	1	1	1	0	0	0	0
7	DRAIN	90	0	0	1	0	0	1	0	0	0	0
8	DRY	90	0	0	1	X	0	0	0	1	0	0
	TOTAL	488							0	1	0	1

X - denotes selectable option  
 CLEAN LED stays on until door is opened or cycle is started.

### Wiring Diagram

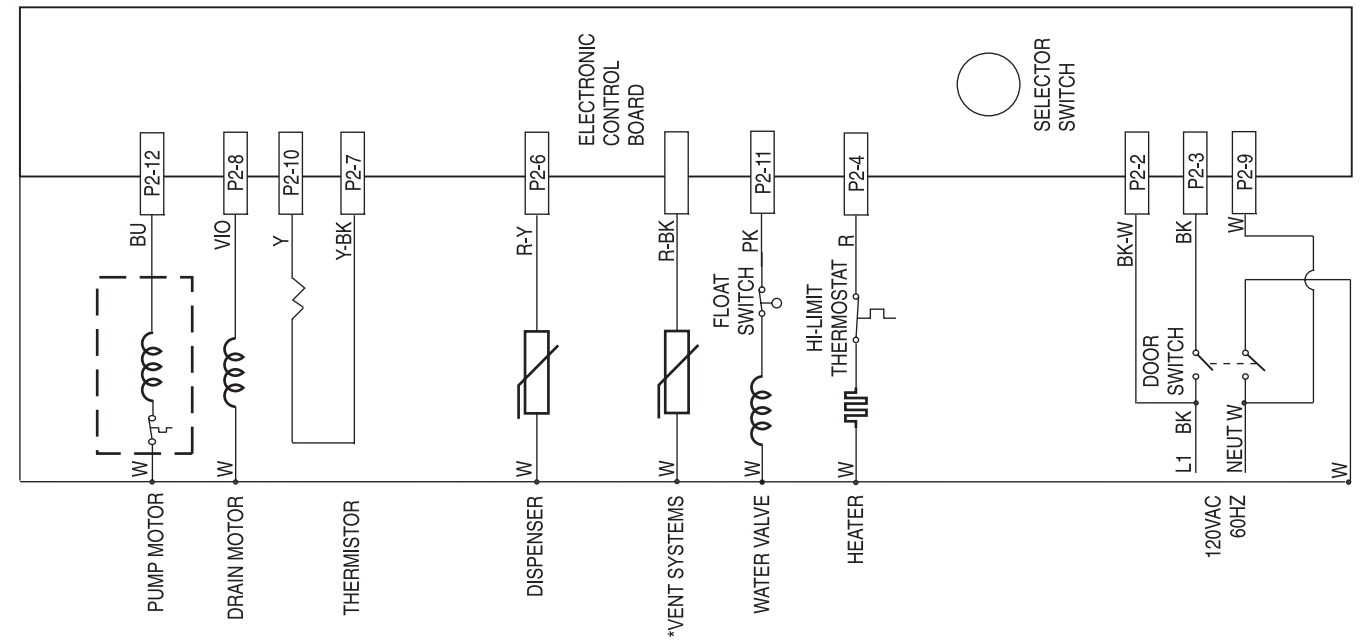

### Cycle Selection Options

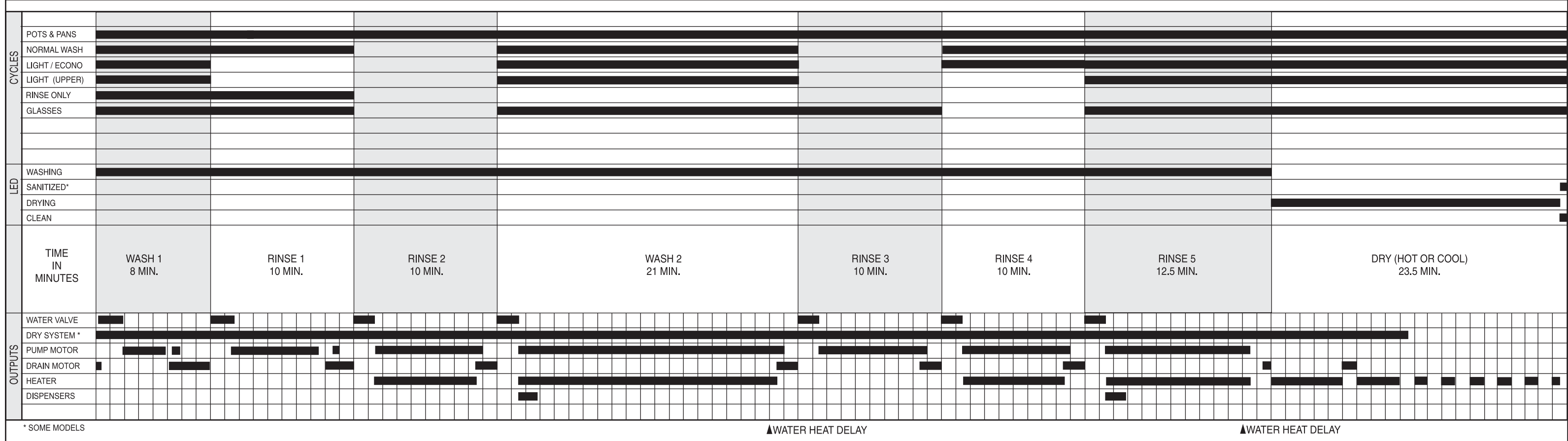

# Exploded View of Wash System

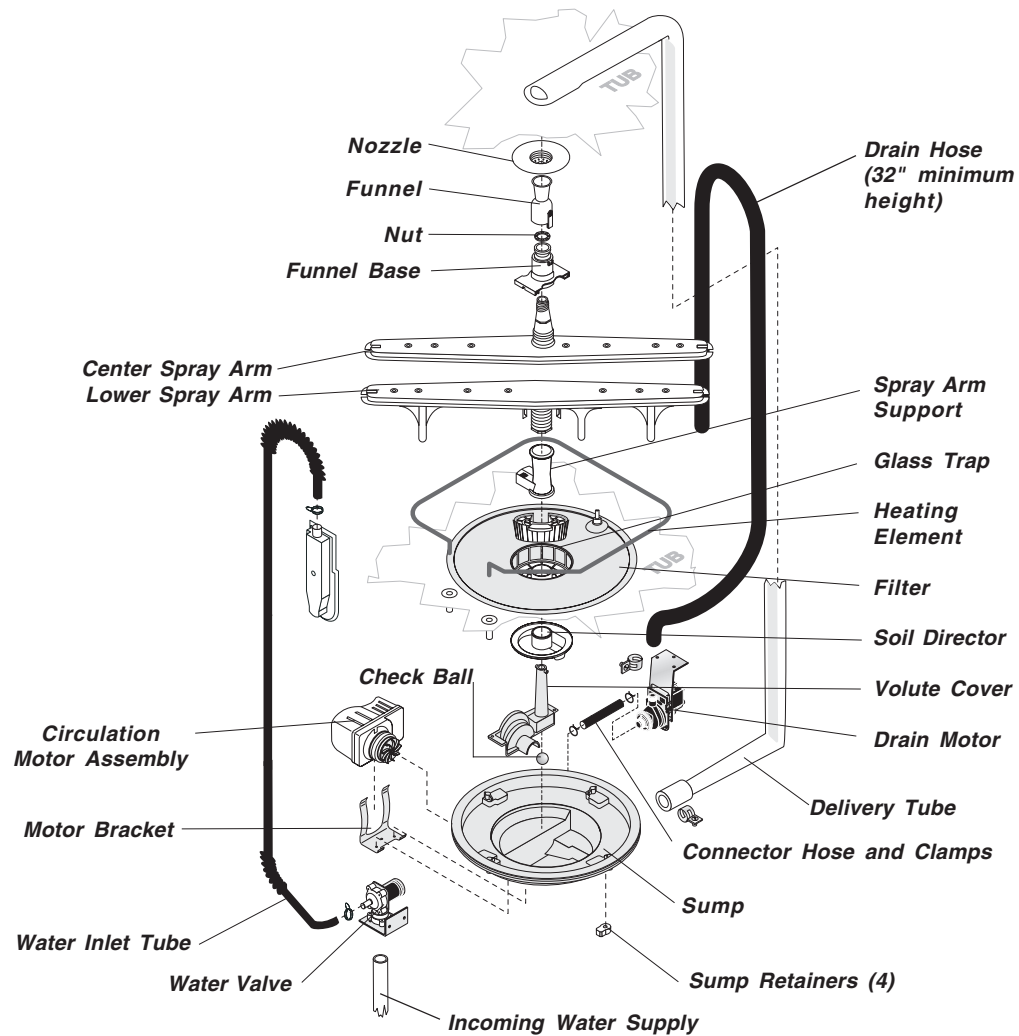

## Pump Assembly

The pump assembly is driven by a synchronous motor. Rotation is in the counterclockwise direction at 3600 RPM. The motor drives a pump which supplies 100 percent filtered water at a rate of approximately 12 GPM to one spray arm at a time. The spray arm's operation is alternated by small "pauses" of the motor during the wash cycle.

Draining is accomplished by using a small separate synchronous drain pump mounted to the side of the sump. The drain pump is connected to the main pump by a small rubber hose. The drain check valve is located at the discharge end of the drain pump. The drain hose

is attached by a worm gear clamp to the discharge end of the drain pump.

The drain hose must have a loop at a **minimum height of 32 inches** in order to insure proper drainage.

The main pump can easily be removed by disconnecting the upper spray arm supply tube hose, the drain pump connector hose, the wiring harness connections made at the circulation motor, the water heat thermistor located on the bottom of the pump and rotating the four sump retainers toward the middle of the sump.

## 900 Watt Heater

Refer to the cycle chart on the reverse side to determine when the heater is on during the wash cycle. The heater cycles **ON** and **OFF** for brief periods during the drying cycle.

Voltage checks of the heater should be made in the dry portion of the service test mode.

## Standard Dry Air Flow

When the control advances to the "dry" portion of the cycle, a linear actuator retracts a valve, which opens a vent path through the console into the kitchen. The heated, moist air leaving the dishwasher through the console vent causes drier air to be drawn into the unit by way of intake

vents located at the bottom of the door. The water on the dishes is evaporated into drier air and the venting process continues. The heating element is turned **ON** and **OFF** during the entire drying cycle.

## Detergent and Rinse Aid Dispenser

The detergent and rinse aid dispenser is a one piece component consisting of a molded detergent cup and a built-in rinse aid dispenser.

The detergent cup has a spring loaded cover and the rinse aid dispenser has a removable cover.

Liquid rinse aid is added to the dispenser up to the fill line indicator. The amount of rinse aid released can be adjusted by turning the arrow indicator from one, being the least amount, to four, being the greatest amount.

### To replace dispenser:

- shut off electricity to dishwasher,
- remove outer door panel assembly,
- disconnect wiring to the actuator,
- remove the six screws,
- remove the dispenser,
- replace and reinstall screws,
- rewire actuator.

## Tub and Door Seal

The door seal is pressed into the tub channel for an interference fit. Center the gasket (marked on back) at the tub top center and press in place

without stretching or bunching. The gasket takes a short turn at the bottom of the tub channel before ending at the channel end wall.

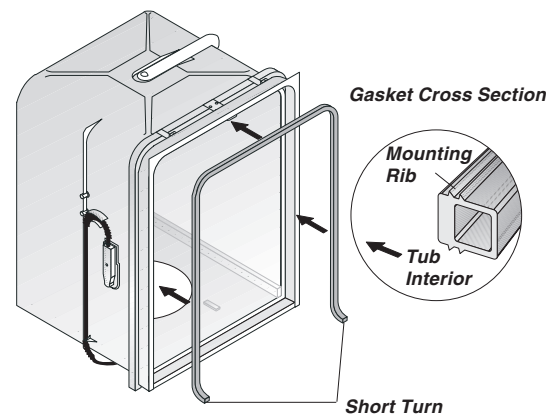

## Product Specifications

### Electrical

Rating .....	120 Volts, 60Hz
Separate Circuit..15 amp min.- 20 amp max.	
Motor (Amps) .....	0.6
Heater Wattage .....	900
Total Amps (load rated) .....	10.0
TempAssure .....	140°F ±5°F (60°C±3°C) [with outer door in place]
TempBoost.....	145°F ±5°F (63°C ±3°C)
	Heated Wash/Heated Rinse
Sanitize .....	155°F ±5°F (66°C ±3°C)
Hi-Limit Thermostat .....	200°F (93°C)

### Water Supply

Suggested minimum incoming water temperature .....	120°F (49°C)
Pressure (PSI) min./max. ....	20/120
Connection (NPT) .....	3/8"
Consumption (Normal Cycle) .....	4.9 - 9.7 U.S. gal., 18.5 - 36.7 liters
Water valve flow rate (U.S. GPM) .....	.83
Water recirculation rate (U.S. GPM) .....	approx. 12
Water fill time .....	87 sec.

# Trouble Shooting Tips

## ⚠ WARNING

### Personal Injury Hazard

Always disconnect the dishwasher from the electrical power source before adjusting or replacing components.

Symptom	Check the Following	Remedy
Dishwasher will not operate when turned on.	<ol style="list-style-type: none"> <li>1. Fuse (blown or tripped).</li> <li>2. 120 VAC supply wiring connection faulty.</li> <li>3. Electronic control board defective.</li> <li>4. Motor (inoperative).</li> <li>5. Door switch (open contacts).</li> <li>6. Door latch not making contact with door switch.</li> <li>7. Touch pad circuit defective.</li> <li>8. No indicator lamps illuminate when START or OPTIONS are pressed.</li> </ol>	<ol style="list-style-type: none"> <li>1. Replace fuse or reset breaker.</li> <li>2. Repair or replace wire fasteners at dishwasher junction box.</li> <li>3. Replace control module.</li> <li>4. Replace motor/impeller assembly.</li> <li>5. Replace latch assembly.</li> <li>6. Replace latch assembly.</li> <li>7. Replace console assembly.</li> <li>8. Replace console assembly.</li> </ol>
Motor hums but will not start or run.	<ol style="list-style-type: none"> <li>1. Motor (bad bearings).</li> <li>2. Motor stuck due to prolonged non-use.</li> </ol>	<ol style="list-style-type: none"> <li>1. Replace motor assembly.</li> <li>2. Rotate motor impeller.</li> </ol>
Motor trips out on internal thermal overload protector.	<ol style="list-style-type: none"> <li>1. Improper voltage.</li> <li>2. Motor windings shorted.</li> <li>3. Glass or foreign items in pump.</li> </ol>	<ol style="list-style-type: none"> <li>1. Check voltage.</li> <li>2. Replace motor/impeller assembly.</li> <li>3. Clean and clear blockage.</li> </ol>
Dishwasher runs but will not heat.	<ol style="list-style-type: none"> <li>1. Heater element (open).</li> <li>2. Electronic control board defective.</li> <li>3. Wiring or terminal defective.</li> <li>4. Hi-Limit thermostat defective.</li> </ol>	<ol style="list-style-type: none"> <li>1. Replace heater element.</li> <li>2. Replace control module.</li> <li>3. Repair or replace.</li> <li>4. Replace thermostat.</li> </ol>
Detergent cover will not latch or open.	<ol style="list-style-type: none"> <li>1. Latch mechanism defective.</li> <li>2. Electronic control board defective.</li> <li>3. Wiring or terminal defective.</li> <li>4. Broken spring(s).</li> <li>5. Defective actuator.</li> </ol>	<ol style="list-style-type: none"> <li>1. Replace dispenser.</li> <li>2. Replace control module.</li> <li>3. Repair or replace.</li> <li>4. Replace dispenser.</li> <li>5. Replace dispenser.</li> </ol>
Dishwasher will not pump out.	<ol style="list-style-type: none"> <li>1. Drain restricted.</li> <li>2. Electronic control board defective.</li> <li>3. Defective drain pump.</li> <li>4. Blocked impeller.</li> <li>5. Open windings.</li> <li>6. Wiring or terminal defective.</li> </ol>	<ol style="list-style-type: none"> <li>1. Clear restrictions.</li> <li>2. Replace control module.</li> <li>3. Replace pump.</li> <li>4. Check for blockage, clear.</li> <li>5. Replace pump assembly.</li> <li>6. Repair or replace.</li> </ol>
Dishwasher will not fill with water.	<ol style="list-style-type: none"> <li>1. Water supply turned off.</li> <li>2. Defective water inlet fill valve.</li> <li>3. Check fill valve screen for obstructions.</li> <li>4. Defective float switch.</li> <li>5. Electronic control board defective.</li> <li>6. Wiring or terminal defective.</li> <li>7. Float stuck in "UP" position.</li> </ol>	<ol style="list-style-type: none"> <li>1. Turn water supply on.</li> <li>2. Replace water inlet fill valve.</li> <li>3. Disassemble and clean screen.</li> <li>4. Repair or replace.</li> <li>5. Replace control module.</li> <li>6. Repair or replace.</li> <li>7. Clean float.</li> </ol>
Dishwasher water siphons out.	<ol style="list-style-type: none"> <li>1. Drain hose (high) loop too low.</li> <li>2. Drain line connected to a floor drain not vented.</li> </ol>	<ol style="list-style-type: none"> <li>1. Repair to proper <b>32-inch minimum height</b>.</li> <li>2. Install air gap at counter top.</li> </ol>
Detergent left in dispenser.	<ol style="list-style-type: none"> <li>1. Detergent allowed to stand too long in dispenser.</li> <li>2. Dispenser wet when detergent was added.</li> <li>3. Detergent cover held closed or blocked by large dishes.</li> <li>4. Improper incoming water temperature to properly dissolve detergent.</li> <li>5. See "Detergent cover will not open."</li> </ol>	<ol style="list-style-type: none"> <li>1. Instruct customer/user.</li> <li>2. Instruct customer/user.</li> <li>3. Instruct customer/user on proper loading of dishes.</li> <li>4. Incoming water temperature of 120°F is required to properly dissolve dishwashing detergents.</li> </ol>